

SECTION 6 –Tooling

! WARNING!

*Only trained personnel familiar with operation should use the FP250.
Always make sure the FP250 tools are in good condition and aligned and centered with track components before pressing.
Be aware of track pins that are worn at an angle. Tooling can break away AND BECOME DANGEROUS under high forces!
Always wear eye protection when operating the FP250.*

! CAUTION!

*Track condition affects the disassembly force, and some track models may exceed the capacity of the FP250.
It is the operator's responsibility to determine whether the FP250 is adequate for a particular track.*

The Tool Chart (starting on page 13) show the correct tooling for most crawler track models. For track models not listed, the drawing (below) shows the size ranges for Forcing Pins, Pin Adapters and Backing Bushings. See www.WTCmachinery.com for updated tool charts

Forcing Pins		
Item	Part No.	Description
1	A3536	Pin Tool - (0.87" to 1.25" (22 to 31,7 mm))
2	A3537	Pin Tool - (1.25" to 1.37" (31.7 to 34,9 mm))
3	B3635	Pin Tool - (1.37" to 1.87" (34,9 to 47,6 mm))
4	B3815	Pin Tool - (1.87" to 2.12" (47,6 to 53,8 mm))
5	B3608	Pin Tool (short) - (2.12" to 2.50" (53,8 to 63,5 mm))
6	B3607	Pin Tool (long) - (2.12" to 2.50" (53,8 to 63,5 mm))
7	B3631	Pin Tool (short) - (2.50" to 3.00" (63,5 to 76,2 mm))
8	B3632	Pin Tool (long) - (2.50" to 3.00" (63,5 to 76,2 mm))

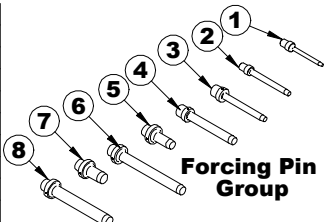

200281	0.86" to 1.17"
25498	1.17" to 1.30"
25499	1.30" to 1.42"
25500	1.42" to 1.55"
25547	1.55" to 1.67"
25548	1.67" to 1.80"
25551	1.80" to 1.98"
25501	1.98" to 2.25"
25553	2.37" to 2.63"
25554	2.75" to 3.0"
Part	Pin Diameter

Optional Forcing Pins
(Not Shown)

FP250 Backing Bushings			
Item	Part Number	Description	Pin Size Range
9	A3539	Small Backing Bushing	1.25" (31,8mm) and Smaller
10	A3540	Medium Backing Bushing	1.25" to 1.75" (31,8 to 44,5mm)
11	A3541	Large Backing Bushing	1.75" to 2.5" (44,5 to 63,5mm)
12	A3541-001	Extra Large Backing	2.125" to 2.875" (53,9 to 73mm)
13	A4157	Extra-Large Bushing	2.75" to 3.00" (70 to 76 mm)

Pin Adapters		
Item	Part Number	Min/Max Pin Dia.
14	50-007-009	0.63" to 0.84" (15,9 to 21,4 mm)
15	50-007-008	0.84" to 0.94" (21,4 to 23,8 mm)
16	50-007-007	0.94" to 1.09" (23,8 to 27,7 mm)
17	50-007-006	1.09" to 1.22" (27,7 to 30,9 mm)
18	50-007-005	1.22" to 1.34" (30,9 to 34,1 mm)
19	50-007-004	1.34" to 1.47" (34,1 to 37,3 mm)
20	50-007-010	1.47" to 1.60" (37,3 to 40,7 mm)
21	50-007-003	1.60" to 1.72" (40,7 to 43,6 mm)
22	50-007-002	1.72" to 1.97" (43,6 to 50,0 mm)
23	50-007-001	1.97" to 2.22" (50,0 to 56,3 mm)
24	50-021-1	2.00" to 2.25" (50 to 57 mm)
25	50-021-2	2.25" to 2.50" (57 to 63 mm)
26	50-021-3	2.50" to 2.75" (63 to 70 mm)
27	50-021-4	2.75" to 3.00" (70 to 76mm)

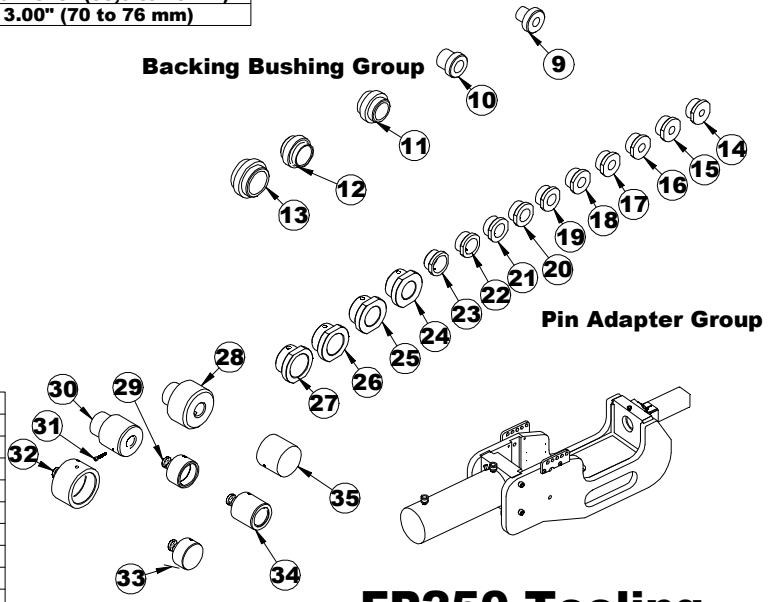

Misc. Adapter Group		
Item	Part Number	Description
28	*A3535	Small Pin Tool Holder
29	*50-008-002	Pin Adapter Holder
30	*B2866	Cylinder-Side Cam-Lock Adapter
31	*529-522	Pin Locking Bolt
32	*50-020	Large Track Pin Holder
33	*50-008-001	Pin Assembly Tool
34	Pin Ass'y Tool	See Tooling Chart
35	*B2867	Backing Bar-Side Cam-Lock

* Items Included With FP250

FP250 Tooling

**CYLINDER-SIDE ADAPTERS
ALL MODELS**

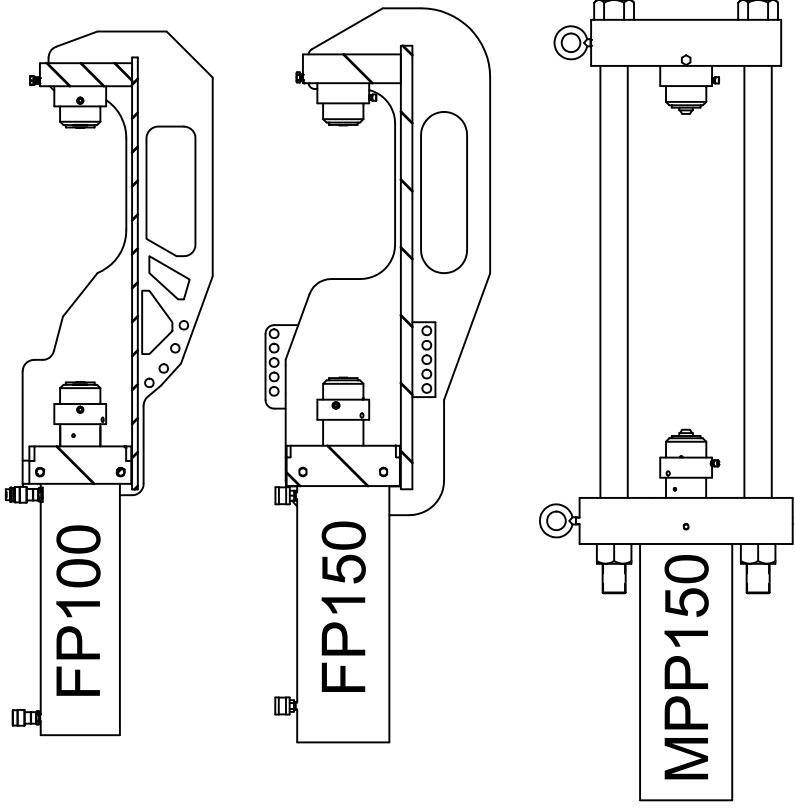
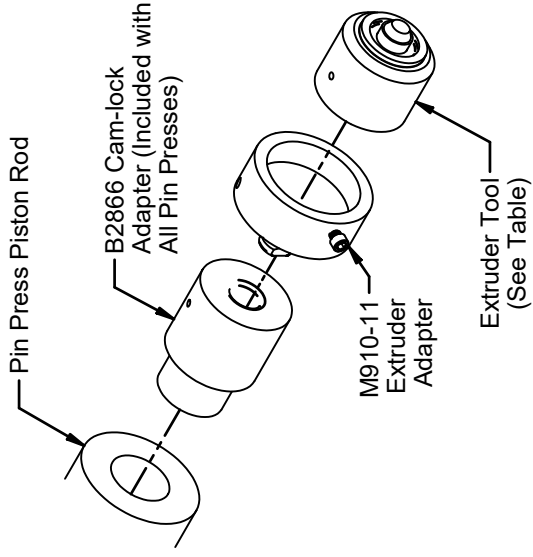

**BACK-SIDE ADAPTERS
FP100, FP150, MPP150**

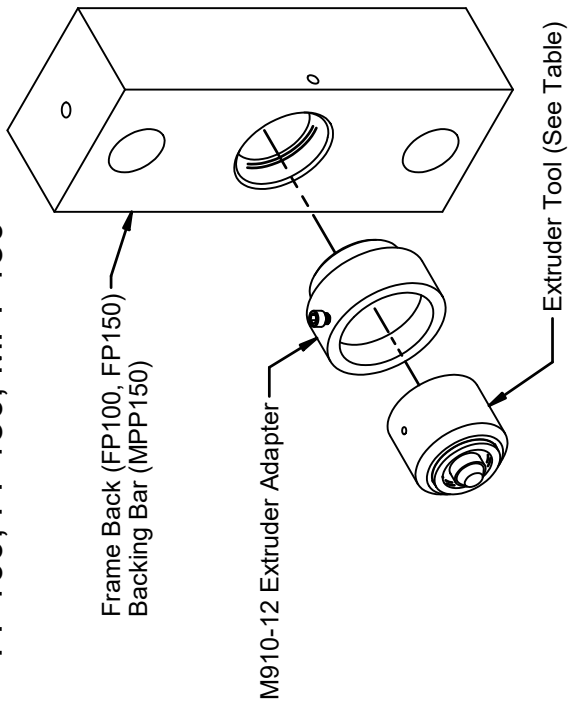

TRACK	CATERPILLAR PPR EXTRUDER TOOL	BERCO BPR2 EXTRUDER TOOL
D8N/R/T	M910-010	M910-010B
D9N/R/T	M910-1	M910-1B
D10 /N/R/T	M910-2*	M910-2B*
D11N/R/T	M910-3**	M910-3B**

Note: Extruder Tools Sold Individually - 2 Required

* - Exceeds FP100 Capacity

** - Exceeds FP100, FP150 and MPP150 Capacity

**BACK-SIDE ADAPTERS
FP250, MPP250**

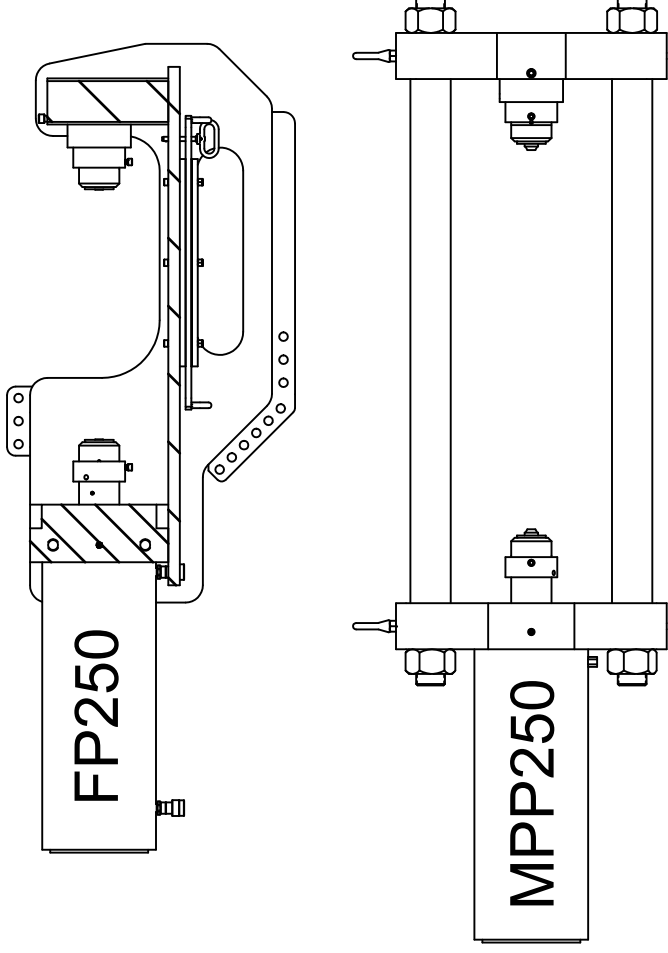
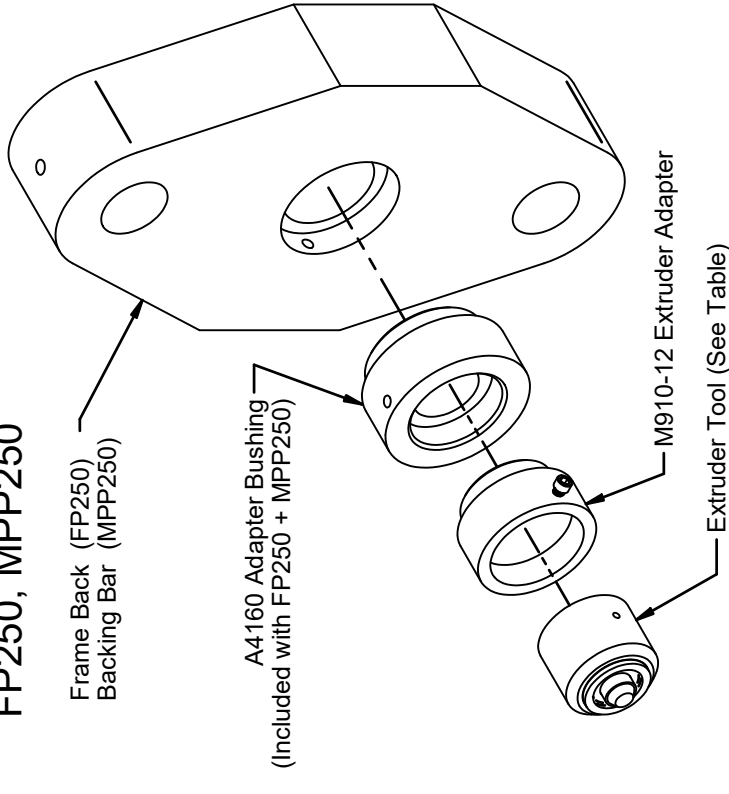

WTC Machinery, LLC

W1222 LINDEN ROAD
IXONIA, WISCONSIN 53036 USA

THIS DRAWING IS THE PROPERTY OF
WTC MACHINERY LLC.
DO NOT USE, DISTRIBUTE OR COPY
WITHOUT EXPRESS PERMISSION

BREAK ALL SHARP EDGES
DO NOT SCALE DRAWING

TOLERANCES UNLESS
OTHERWISE SPECIFIED
FABRICATED DIMENSIONS +/- .1/16
FRACTIONAL DIMENSIONS +/- .1/64
DECIMAL DIMENSIONS +/- .010
INSIDE RADIUS 1/32
ANGULAR DIMENSIONS +/- .1/2
SURFACE FINISH 125

NEXT ASSEMBLY

FP / MPP Portable Pin Presses

USED ON

Caterpillar PPR Track Chains

TITLE

Caterpillar PPR Tracks
Pin Press Extruder Tools and Adapters

SHEET

DATE 22.05.10

DRAWING NUMBER

REV

DRAWN
Solid Edge

WGT N/A

SIZE B

FP/MPP-ETA

A

CYLINDER-SIDE ADAPTERS - ALL MODELS

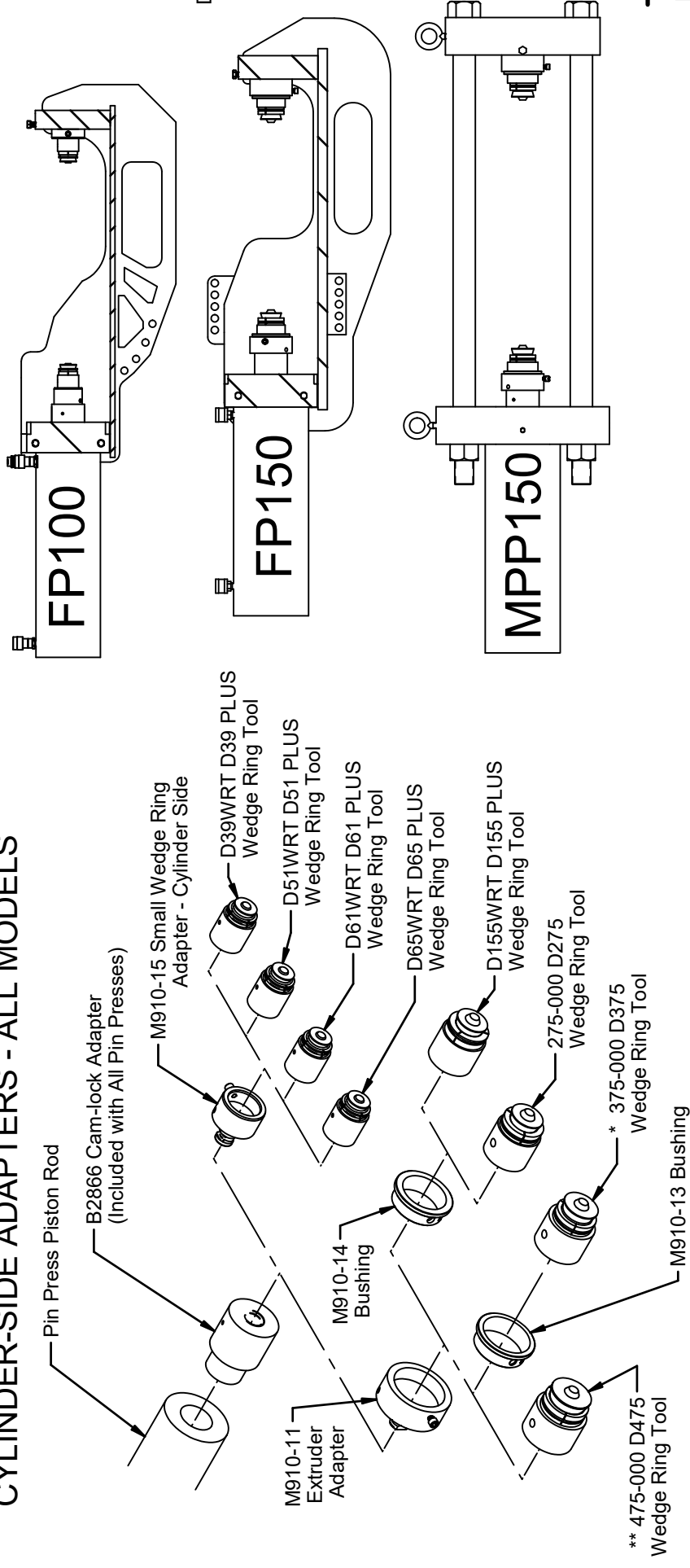

** 475-000 D475
Wedge Ring Tool

* 375-000 D375
Wedge Ring Tool

M910-13 Bushing

BACK-SIDE ADAPTERS - FP100, FP150, MPP150

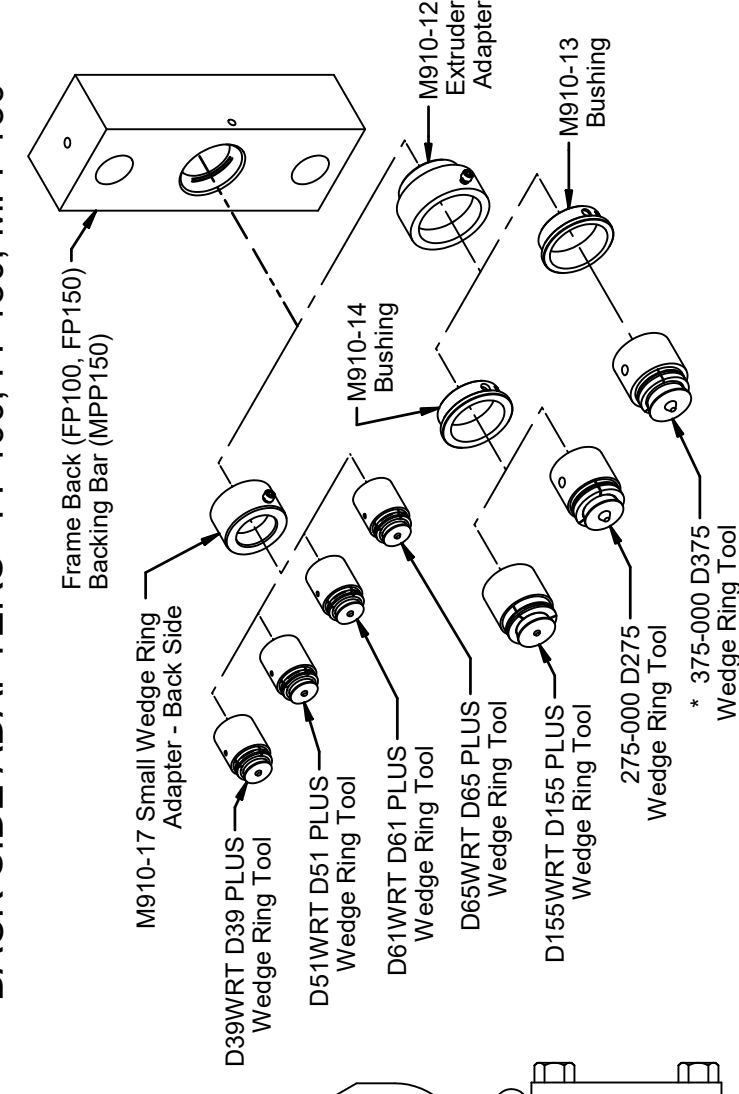

* 375-000 D375
Wedge Ring Tool

BACK-SIDE ADAPTERS - FP250, MPP250

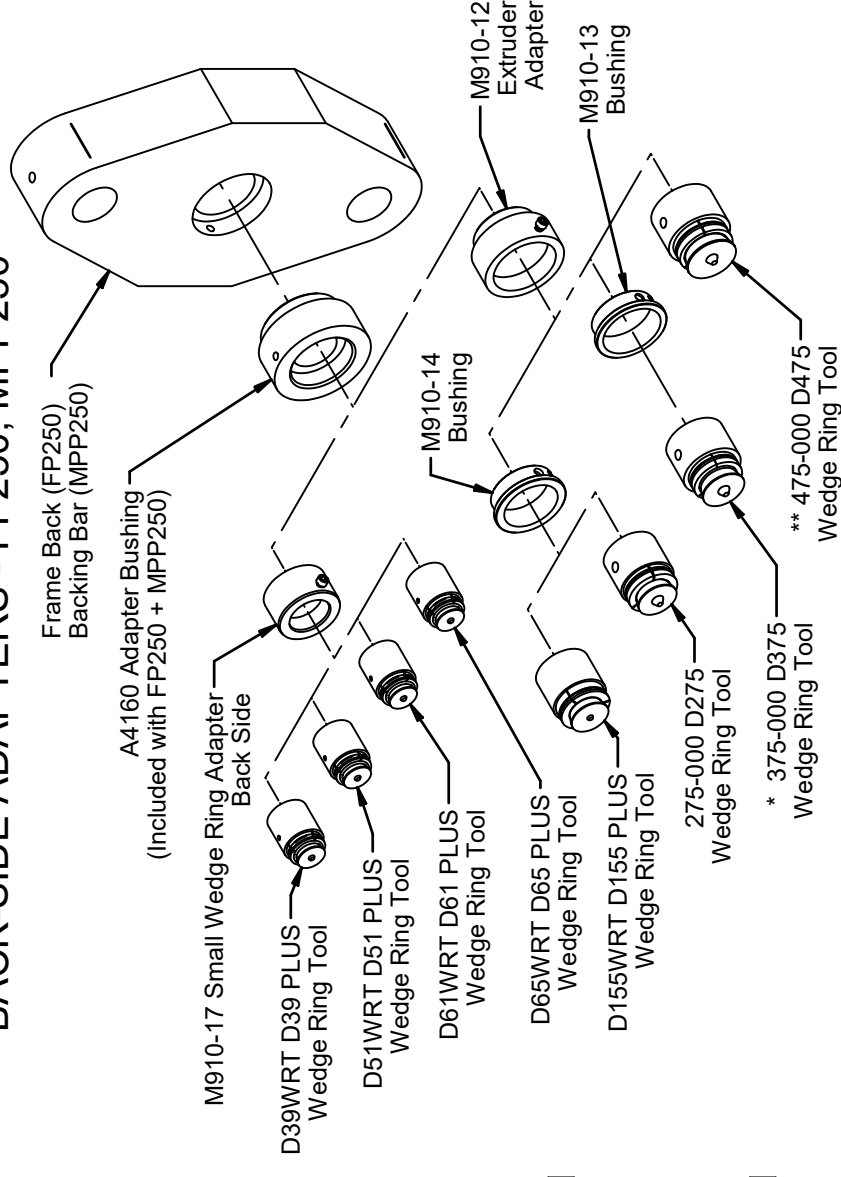

* 375-000 D375
Wedge Ring Tool

** 475-000 D475
Wedge Ring Tool

Note: Wedge Ring Tools Sold in Sets
 Each set includes -
 - one Large End Tool (Rubber Plug end)
 - one Small End Tool (Plastic Plug end)

* Exceeds Capacity of FP100

** Exceeds Capacity of FP100, FP150 and MPP150

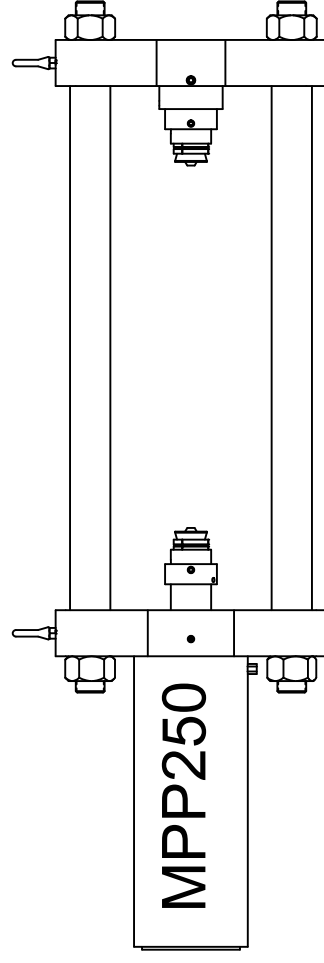
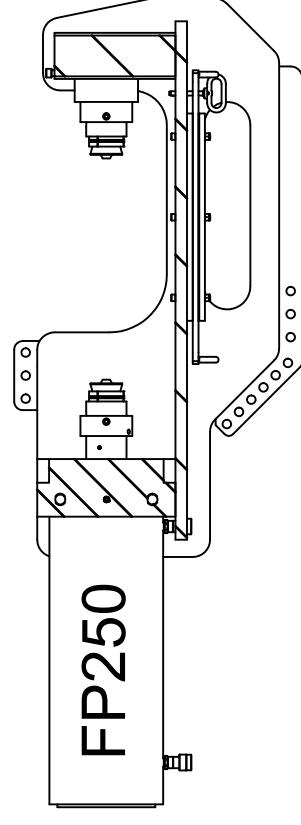
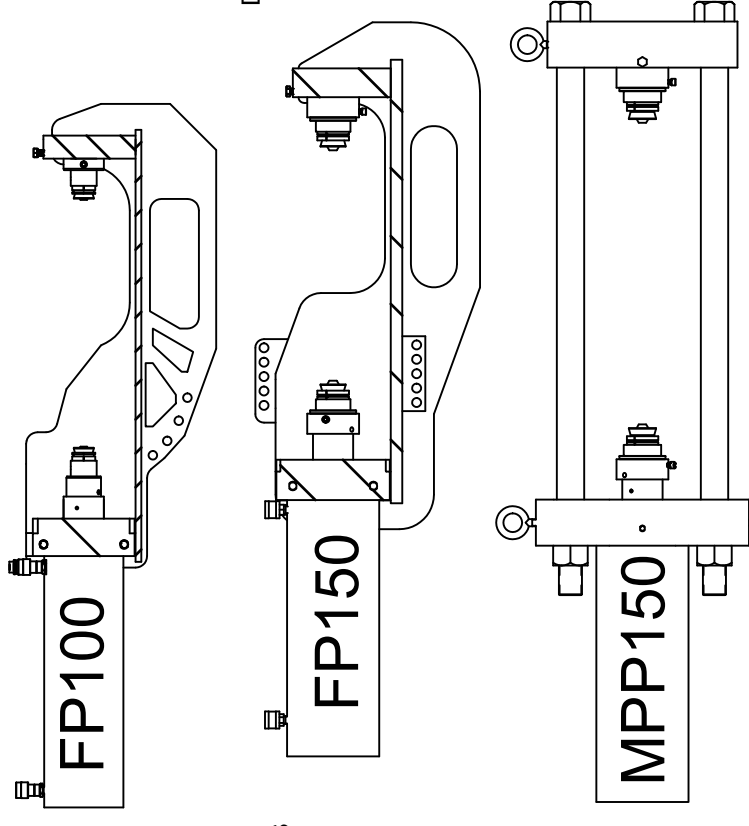

WTC Machinery, LLC
 W1222 LINDEN ROAD
 IXONIA, WISCONSIN 53036 USA

THIS DRAWING IS THE PROPERTY OF
 WTC MACHINERY, LLC.
 DO NOT USE, DISTRIBUTE OR COPY
 WITHOUT EXPRESS PERMISSION
 BREAK ALL SHARP EDGES
 DO NOT SCALE DRAWING

TOLERANCES UNLESS
 OTHERWISE SPECIFIED
 FABRICATED DIMENSIONS +/- .1/16
 FRACTIONAL DIMENSIONS +/- .1/64
 DECIMAL DIMENSIONS +/- .010
 INSIDE RADII 1/32
 ANGULAR DIMENSIONS +/- .1/2
 SURFACE FINISH 125

NEXT ASSEMBLY
 FP / MPP Portable Pin Presses

USED ON
 Komatsu Wedge Ring Track Chains

TITLE
 Komatsu Wedge Ring Tracks

SHEET
 Pin Press Wedge Ring Tools and Adapters

DATE 22.05.10

WGT N/A

SIZE B

DRAWING NUMBER
 FP/MPP-WRTA

REV A



WTC Machinery FP250 Tooling Chart

6/9/2022

Make	Model	Comments	Type	Pin Dimensions			Disassembly Tools		Assembly Tools		
				Dia	Length	Pitch	Pin Tool	Back. Bush.	PAT (2)	Forcing Pin	Bushing
CASE	350		FLUSH	0.993	5.22	5.88	A3536	A3539	915068	200281	50-007-007
CASE	400		FLUSH	0.993	5.22	5.88	A3536	A3539	915068	200281	50-007-007
CASE	420		FLUSH	0.993	5.22	5.88	A3536	A3539	915068	200281	50-007-007
CASE	450		FLUSH	1.187	5.38	5.75	A3536	A3539	915066	25498	50-007-006
CASE	450			1.0625	5.375	5.88	A3536	A3539	915225	200281	50-007-007
CASE	500		FLUSH	0.993	5.22	5.88	A3536	A3539	915068	200281	50-007-007
CASE	550		SALT	1.129	6.575	6.29	A3536	A3539	915144	200281	50-007-006
CASE	550	JAK0013968 & DN	SEALED	1.129	6.457	6.00	A3536	A3539	915066	200281	50-007-006
CASE	550		SEALED	1.129	6.575	6.29	A3536	A3539	915144	200281	50-007-006
CASE	560		FLUSH	0.993	5.22	5.88	A3536	A3539	915068	200281	50-007-007
CASE	600			1.0625	5.375	5.88	A3536	A3539	915225	200281	50-007-007
CASE	650		SALT	1.318	7.224	6.74	A3537	A3540	915158	25499	50-007-005
CASE	650		SEALED	1.318	7.224	6.73	A3537	A3540	915011	25499	50-007-005
CASE	700	S/N 7070351 & DN	RECESSED	1.248	6.5	6.25	A3536	A3539	915056	25498	50-007-005
CASE	750		RECESSED	1.375	6.94	6.25	B3635	A3541	915069	25499	50-007-004
CASE	800		RECESSED	1.248	6.5	6.25	A3536	A3539	915056	25498	50-007-005
CASE	850		SEALED	1.375	6.94	6.25	B3635	A3541	915009	25499	50-007-004
CASE	1000		RECESSED	1.248	6.5	6.25	A3536	A3539	915056	25498	50-007-005
CASE	1000	HD	RECESSED	1.375	6.94	6.25	B3635	A3541	915069	25499	50-007-004
CASE	1000		SEALED	1.375	6.94	6.25	B3635	A3541	915009	25499	50-007-004
CASE	1150		RECESSED	1.375	6.94	6.25	B3635	A3541	915069	25499	50-007-004
CASE	1150		SEALED	1.375	6.94	6.25	B3635	A3541	915009	25499	50-007-004
CASE	1150		SEALED	1.375	6.94	6.25	B3635	A3541	915011	25499	50-007-004
CASE	1450		SEALED	1.752	9.075	8.02	B3635	A3541	915070	25548	50-007-002
CASE	1550		SALT	1.753	9.06	8.02	B3635	A3541	915006	25548	50-007-002
CASE	1550		SEALED	1.753	9.06	8.02	B3635	A3541	915226	25548	50-007-002
CASE	1150B		SEALED	1.5	8.1	6.68	B3635	A3541	915067	25500	50-007-010
CASE	1150D	7310051 & PRIOR	SEALED	1.44	8.11	6.68	B3635	A3541	915052	25500	50-007-004
CASE	1150D	7310051 & PRIOR	SALT	1.44	8.11	6.68	B3635	A3541	915052	25500	50-007-004
CASE	1150E		SALT	1.44	8.11	6.68	B3635	A3541	915052	25500	50-007-004
CASE	1150E		SEALED	1.44	8.11	6.68	B3635	A3541	915052	25500	50-007-004
CASE	1155D	7311001 & PRIOR	SALT	1.44	8.11	6.68	B3635	A3541	915052	25500	50-007-004
CASE	1155D	7311001 & PRIOR	SEALED	1.44	8.11	6.68	B3635	A3541	915052	25500	50-007-004
CASE	1155E		SALT	1.44	8.11	6.68	B3635	A3541	915052	25500	50-007-004
CASE	1155E		SEALED	1.44	8.11	6.68	B3635	A3541	915052	25500	50-007-004
CASE	1450B		SALT	1.753	9.06	8.02	B3635	A3541	915006	25548	50-007-002
CASE	1450B		SEALED	1.752	9.075	8.02	B3635	A3541	915070	25548	50-007-002
CASE	1450B	S/N 8383001 & UP	SEALED	1.753	9.06	8.02	B3635	A3541	915226	25548	50-007-002
CASE	1455B		SALT	1.753	9.06	8.02	B3635	A3541	915006	25548	50-007-002
CASE	1455B		SEALED	1.752	9.075	8.02	B3635	A3541	915070	25548	50-007-002
CASE	1455B	S/N 8480001 & UP	SEALED	1.753	9.06	8.02	B3635	A3541	915226	25548	50-007-002
CASE	310G		FLUSH	0.993	5.22	5.88	A3536	A3539	915068	200281	50-007-007
CASE	350B		SEALED	0.994	5.219	5.88	A3536	A3539	915224	200281	50-007-007
CASE	450A	S/N 3030801 & UP	SEALED	1.25	6.54	6.00	A3537	A3540	915069	25498	50-007-005
CASE	450B		SEALED	1.25	6.54	6.00	A3537	A3540	915069	25498	50-007-005
CASE	450C		SALT	1.129	6.46	6.00	A3536	A3539	915046	200281	50-007-006
CASE	450C		SEALED	1.129	6.457	6.00	A3536	A3539	915066	200281	50-007-006
CASE	455C		SALT	1.129	6.46	6.00	A3536	A3539	915046	200281	50-007-006
CASE	550E		SALT	1.129	6.575	6.29	A3536	A3539	915144	200281	50-007-006
CASE	550E		SEALED	1.129	6.575	6.29	A3536	A3539	915144	200281	50-007-006
CASE	550G	Floating Bushing	SEALED	1.129	6.575	6.29	A3536	A3539	915144	200281	50-007-006
CASE	850B		SEALED	1.375	6.94	6.25	B3635	A3541	915009	25499	50-007-004
CASE	850D		SALT	1.318	7.22	6.25	A3537	A3540	915011	25499	50-007-005
CASE	850D		SALT	1.318	7.224	6.74	A3537	A3540	915158	25499	50-007-005
CASE	850D		SEALED	1.375	6.94	6.25	B3635	A3541	915011	25499	50-007-004
CASE	850D		SEALED	1.318	7.224	6.73	A3537	A3540	915011	25499	50-007-005
CASE	850E	AFTER 4-1-89	SALT	1.318	7.224	6.74	A3537	A3540	915158	25499	50-007-005
CASE	850E	AFTER 4-1-89	SEALED	1.318	7.224	6.73	A3537	A3540	915011	25499	50-007-005
CASE	850G		SALT	1.318	7.224	6.74	A3537	A3540	915158	25499	50-007-005
CASE	850G		SEALED	1.318	7.224	6.73	A3537	A3540	915011	25499	50-007-005
CASE	850H		SALT	1.318	7.224	6.74	A3537	A3540	915158	25499	50-007-005
CASE	850H		SEALED	1.318	7.224	6.73	A3537	A3540	915011	25499	50-007-005
CASE	850K		SALT	1.318	7.224	6.74	A3537	A3540	915158	25499	50-007-005
CASE	850K		SEALED	1.318	7.224	6.73	A3537	A3540	915011	25499	50-007-005
CASE	855D		SALT	1.318	7.22	6.25	A3537	A3540	915011	25499	50-007-005
CASE	855D	AFTER 4-1-89	SALT	1.318	7.224	6.74	A3537	A3540	915158	25499	50-007-005
CASE	855D		SEALED	1.375	6.94	6.25	B3635	A3541	915011	25499	50-007-004
CASE	855D	AFTER 4-1-89	SEALED	1.318	7.224	6.73	A3537	A3540	915011	25499	50-007-005
CATERPILLAR	30		RECESS	1.314	7	6.74	A3537	A3540	915011	25499	50-007-005



WTC Machinery FP250 Tooling Chart

6/9/2022

Make	Model	Comments	Type	Pin Dimensions			Disassembly Tools		Assembly Tools		
				Dia	Length	Pitch	Pin Tool	Back. Bush.	PAT (2)	Forcing Pin	Bushing
CATERPILLAR	215	w/ 5/8 BOLT	SEALED	1.314	7.22	6.74	A3537	A3540	915011	25499	50-007-005
CATERPILLAR	215	w/ 9/16 BOLT	SEALED	1.315	6.37	6.74	A3537	A3540	915089	25499	50-007-005
CATERPILLAR	219		SEALED	1.442	8.12	7.48	B3635	A3541	915052	25500	50-007-004
CATERPILLAR	225	EXC	SEALED	1.314	7.22	6.74	A3537	A3540	915011	25499	50-007-005
CATERPILLAR	225		SEALED	1.252	9.06	7.98	A3537	A3540	915003	25498	50-007-005
CATERPILLAR	227		SEALED	1.252	9.06	7.98	A3537	A3540	915003	25498	50-007-005
CATERPILLAR	229		SEALED	1.252	9.06	7.98	A3537	A3540	915003	25498	50-007-005
CATERPILLAR	235	EXC	SEALED	1.252	9.06	7.98	A3537	A3540	915003	25498	50-007-005
CATERPILLAR	235		SEALED	1.877	9.88	8.50	B3815	A3541	915012	25551	50-007-002
CATERPILLAR	245	EXC	SEALED	2.253	11.259	10.25	B3607/8	A3541	915005	25553	50-021-2
CATERPILLAR	311	EXC	SEALED	1.321	7.01	6.75	A3537	A3540	915059	25499	50-007-005
CATERPILLAR	312	EXC	SEALED	1.321	7.01	6.75	A3537	A3540	915059	25499	50-007-005
CATERPILLAR	315	EXC	SEALED	1.442	8.15	7.48	B3635	A3541	915140	25500	50-007-004
CATERPILLAR	317	EXC	SEALED	1.442	8.15	7.48	B3635	A3541	915140	25500	50-007-004
CATERPILLAR	320	EXC	SEALED	1.442	8.15	7.48	B3635	A3541	915140	25500	50-007-004
CATERPILLAR	322	EXC	SEALED	1.442	8.15	7.48	B3635	A3541	915140	25500	50-007-004
CATERPILLAR	325	EXC	SEALED	1.654	9.055	8.00	B3635	A3541	915141	25547L	50-007-003
CATERPILLAR	330	EXC	SEALED	1.811	9.665	8.50	B3635	A3541	915015	25551	50-007-002
CATERPILLAR	345	EXC	SEALED	2.003	11.438	8.50	B3815	A3541	915142	25501	50-007-001
CATERPILLAR	350		SEALED	2.003	11.438	9.00	B3815	A3541	915001	25501	50-007-001
CATERPILLAR	365	EXC	SEALED	2.253	12.244	10.25	B3607/8	A3541	915139	25553	50-021-2
CATERPILLAR	375	EXC	SEALED	2.253	12.244	10.25	B3607/8	A3541	915139	25553	50-021-2
CATERPILLAR	561	PIPELAYER	SEALED	1.442	8.125	6.91	B3635	A3541	915009	25500	50-007-004
CATERPILLAR	571		SEALED	1.752	9.875	7.98	B3635	A3541	915012	25548	50-007-002
CATERPILLAR	572		SEALED	1.752	9.875	7.98	B3635	A3541	915012	25548	50-007-002
CATERPILLAR	572		SEALED	1.877	9.88	8.50	B3815	A3541	915012	25551	50-007-002
CATERPILLAR	578		PPR	1.878	9.65	8.50	B3815	A3541	915207	25551	50-007-002
CATERPILLAR	578	PIPELAYER	SALT	1.88	9.88	8.50	B3815	A3541	915006	25551	50-007-002
CATERPILLAR	583		SEALED	1.752	11.438	7.99	B3635	A3541	915013	25548	50-007-002
CATERPILLAR	589		PPR	2	10.77	9.00	B3815	A3541	915253	25501	50-007-001
CATERPILLAR	589	PIPELAYER	SALT	2	11.437	9.00	B3815	A3541	915093	25501	50-007-001
CATERPILLAR	594		SEALED	2.252	12.25	10.25	B3607/8	A3541	915005	25553	50-021-2
CATERPILLAR	931		SALT	1.126	6.161	6.13	A3536	A3539	915082	200281	50-007-006
CATERPILLAR	931		SEALED	1.129	6.156	6.13	A3536	A3539	915004	200281	50-007-006
CATERPILLAR	933		SEALED	1.129	6.156	6.13	A3536	A3539	915004	200281	50-007-006
CATERPILLAR	939		SALT	1.318	7.535	6.74	A3537	A3540	915149	25499	50-007-005
CATERPILLAR	941		SALT	1.314	7.22	6.74	A3537	A3540	915052	25499	50-007-005
CATERPILLAR	941	w/ 9/16 BOLT	SEALED	1.314	7	6.74	A3537	A3540	915002	25499	50-007-005
CATERPILLAR	941	w/ 5/8 BOLT	SEALED	1.314	7.22	6.74	A3537	A3540	915011	25499	50-007-005
CATERPILLAR	943	HI RAIL	SALT	1.314	7.22	6.74	A3537	A3540	915052	25499	50-007-005
CATERPILLAR	943	HI RAIL	SALT	1.315	7.22	6.74	A3537	A3540	915002	25499	50-007-005
CATERPILLAR	951		SALT	1.442	8.12	6.91	B3635	A3541	915052	25500	50-007-004
CATERPILLAR	951		SEALED	1.442	8.125	6.74	B3635	A3541	915009	25500	50-007-004
CATERPILLAR	953	HI RAIL	SALT	1.442	8.12	6.91	B3635	A3541	915052	25500	50-007-004
CATERPILLAR	953		SALT	1.442	8.12	6.91	B3635	A3541	915052	25500	50-007-004
CATERPILLAR	953	LGP	SALT	1.442	8.12	6.91	B3635	A3541	915052	25500	50-007-004
CATERPILLAR	955		SALT	1.753	9.06	7.98	B3635	A3541	915003	25548	50-007-002
CATERPILLAR	955	HD	SEALED	1.442	8.125	6.74	B3635	A3541	915009	25500	50-007-004
CATERPILLAR	955		SEALED	1.252	9.06	7.98	A3537	A3540	915003	25498	50-007-005
CATERPILLAR	963		SALT	1.753	9.06	7.98	B3635	A3541	915003	25548	50-007-002
CATERPILLAR	963	HI RAIL	SALT	1.753	9.06	7.98	B3635	A3541	915003	25548	50-007-002
CATERPILLAR	973		SALT	1.877	9.88	8.50	B3815	A3541	915006	25551	50-007-002
CATERPILLAR	973	HI RAIL	SALT	1.877	9.88	8.50	B3815	A3541	915006	25551	50-007-002
CATERPILLAR	973	LGP	SALT	1.877	9.88	8.50	B3815	A3541	915006	25551	50-007-002
CATERPILLAR	973	HI RAIL	SALT	1.878	9.88	8.50	B3815	A3541	915201	25551	50-007-002
CATERPILLAR	973		SEALED	1.877	9.88	8.50	B3815	A3541	915012	25551	50-007-002
CATERPILLAR	977		SALT	1.877	9.88	8.50	B3815	A3541	915006	25551	50-007-002
CATERPILLAR	977		SEALED	1.442	8.125	6.74	B3635	A3541	915009	25500	50-007-004
CATERPILLAR	977	OPT FORMER	SEALED	1.442	8.125	6.91	B3635	A3541	915009	25500	50-007-004
CATERPILLAR	977		SEALED	1.877	9.88	8.50	B3815	A3541	915012	25551	50-007-002
CATERPILLAR	983		SEALED	2.003	11.438	9.00	B3815	A3541	915001	25501	50-007-001
CATERPILLAR	5080		SEALED	2.253	12.244	10.25	B3607/8	A3541	915139	25553	50-021-2
CATERPILLAR	5130		SALT	2.626	14.173	12.50	B3631/2	A6212	915202	25553L	50-021-3
CATERPILLAR	E70B		SEALED	0.945	5.512	5.32	A3536	A3539	915129	200281	50-007-007
CATERPILLAR	14A		SEALED	1.752	11.438	7.99	B3635	A3541	915013	25548	50-007-002
CATERPILLAR	17A		SEALED	1.752	9.875	7.98	B3635	A3541	915012	25548	50-007-002
CATERPILLAR	215A		SEALED	1.442	8.12	7.48	B3635	A3541	915052	25500	50-007-004
CATERPILLAR	225B	EXC	SEALED	1.442	8.12	7.48	B3635	A3541	915052	25500	50-007-004
CATERPILLAR	225C	EXC	SEALED	1.442	8.12	7.48	B3635	A3541	915052	25500	50-007-004



WTC Machinery FP250 Tooling Chart

6/9/2022

Make	Model	Comments	Type	Pin Dimensions			Disassembly Tools		Assembly Tools		
				Dia	Length	Pitch	Pin Tool	Back. Bush.	PAT (2)	Forcing Pin	Bushing
CATERPILLAR	231D		SEALED	1.252	9.06	7.98	A3537	A3540	915003	25498	50-007-005
CATERPILLAR	235D		SEALED	2.003	11.438	9.00	B3815	A3541	915001	25501	50-007-001
CATERPILLAR	245S		SEALED	2.003	11.438	9.00	B3815	A3541	915001	25501	50-007-001
CATERPILLAR	307C		GREASE	0.94	5.15	6.06	A3536	A3539	915169	200281	50-007-007
CATERPILLAR	312C	EXC	GREASE	1.32	7	6.75	A3537	A3540	915059	25499	50-007-005
CATERPILLAR	313B	EXC	SEALED	1.321	7.01	6.75	A3537	A3540	915059	25499	50-007-005
CATERPILLAR	314B	EXC	SEALED	1.321	7.01	6.75	A3537	A3540	915059	25499	50-007-005
CATERPILLAR	315B	EXC	GREASE	1.442	8.15	7.48	B3635	A3541	915236	25500	50-007-004
CATERPILLAR	315C	EXC	GREASE	1.442	8.15	7.48	B3635	A3541	915170	25500	50-007-004
CATERPILLAR	318C	EXC	GREASE	1.442	8.15	7.48	B3635	A3541	915170	25500	50-007-004
CATERPILLAR	320B	EXC	SEALED	1.442	8.15	7.48	B3635	A3541	915140	25500	50-007-004
CATERPILLAR	320C	EXC	GREASE	1.442	8.15	7.48	B3635	A3541	915170	25500	50-007-004
CATERPILLAR	322B	EXC	GREASE	1.442	8.15	7.48	B3635	A3541	915236	25500	50-007-004
CATERPILLAR	322C	EXC	GREASE	1.442	8.15	7.48	B3635	A3541	915170	25500	50-007-004
CATERPILLAR	325BL	EXC	SEALED	1.654	9.055	8.00	B3635	A3541	915141	25547L	50-007-003
CATERPILLAR	325C	EXC	GREASE	1.65	9.05	7.99	B3635	A3541	915141	25547L	50-007-003
CATERPILLAR	330B	EXC	GREASE	1.811	9.665	8.50	B3635	A3541	915185	25551	50-007-002
CATERPILLAR	330B	EXC	SEALED	1.811	9.665	8.50	B3635	A3541	915015	25551	50-007-002
CATERPILLAR	330C	EXC	SEALED	1.811	9.665	8.50	B3635	A3541	915015	25551	50-007-002
CATERPILLAR	345B	EXC	SALT	1.877	9.882	8.50	B3815	A3541	915200	25551	50-007-002
CATERPILLAR	345B		SEALED	1.877	9.88	8.50	B3815	A3541	915012	25551	50-007-002
CATERPILLAR	345BL	EXC	SALT	1.877	9.882	8.50	B3815	A3541	915200	25551	50-007-002
CATERPILLAR	365BL	EXC	SEALED	2.253	12.244	10.25	B3607/8	A3541	915139	25553	50-021-2
CATERPILLAR	385B	EXC	SEALED	2.253	13.188	10.25	B3607/8	A3541	915168	25553L	50-021-2
CATERPILLAR	390	EXC	SEALED	2.165	12.41	10.25	B3607/8	A3541	915284	25501L	50-007-001
CATERPILLAR	561H		SALT	1.318	7.535	6.74	A3537	A3540	915149	25499	50-007-005
CATERPILLAR	561H	HD	SALT	1.418	8.445	6.74	B3635	A3541	915145	25499	50-007-004
CATERPILLAR	571A		SALT	1.877	9.88	8.50	B3815	A3541	915006	25551	50-007-002
CATERPILLAR	571A		SEALED	1.877	9.88	8.50	B3815	A3541	915012	25551	50-007-002
CATERPILLAR	583R	PIPELAYER	SALT	1.88	9.88	8.50	B3815	A3541	915006	25551	50-007-002
CATERPILLAR	933	CURRENT	SALT	1.126	6.161	6.13	A3536	A3539	915082	200281	50-007-006
CATERPILLAR	935B		SALT	1.126	6.161	6.13	A3536	A3539	915082	200281	50-007-006
CATERPILLAR	935B		SEALED	1.129	6.156	6.13	A3536	A3539	915004	200281	50-007-006
CATERPILLAR	935C		SALT	1.126	6.161	6.13	A3536	A3539	915082	200281	50-007-006
CATERPILLAR	951B		SEALED	1.442	8.125	6.74	B3635	A3541	915009	25500	50-007-004
CATERPILLAR	951B		SEALED	1.442	8.125	6.91	B3635	A3541	915009	25500	50-007-004
CATERPILLAR	951C		SEALED	1.442	8.125	6.91	B3635	A3541	915009	25500	50-007-004
CATERPILLAR	955K		SEALED	1.442	8.125	6.91	B3635	A3541	915009	25500	50-007-004
CATERPILLAR	977K		SEALED	1.752	9.875	7.98	B3635	A3541	915012	25548	50-007-002
CATERPILLAR	983		SALT	2.002	11.438	9.00	B3815	A3541	915007	25501	50-007-001
CATERPILLAR	AP1050		SEALED	1.129	6.156	6.13	A3536	A3539	915004	200281	50-007-006
CATERPILLAR	D10		PPR	2.252	11.974	10.25	B3607/8	A3541	915240	25553	50-021-2
CATERPILLAR	D10		SALT	2.253	12.25	10.25	B3607/8	A3541	915063	25553	50-021-2
CATERPILLAR	D10N		PPR	2.253	11.97	10.25	B3607/8	A3541	915246	25553	50-021-2
CATERPILLAR	D10N		SALT	2.253	12.25	10.25	B3607/8	A3541	915104	25553	50-021-2
CATERPILLAR	D10R		PPR	2.253	11.97	10.25	B3607/8	A3541	915246	25553	50-021-2
CATERPILLAR	D10R		SALT	2.253	12.25	10.25	B3607/8	A3541	915104	25553	50-021-2
CATERPILLAR	D10T		SALT	2.253	12.25	10.25	B3607/8	A3541	915104	25553	50-021-2
CATERPILLAR	D11		SALT	2.626	13.81	12.50	B3631/2	A6212	915202	25553L	50-021-3
CATERPILLAR	D11N		PPR	2.626	13.81	12.50	B3631/2	A6212	915203	25553L	50-021-3
CATERPILLAR	D11R		PPR	2.626	13.81	12.50	B3631/2	A6212	915203	25553L	50-021-3
CATERPILLAR	D2		RECESS	1.127	6.156	6.13	A3536	A3539	916040	200281	50-007-006
CATERPILLAR	D2		SEALED	1.125	6.18	6.13	A3536	A3539	915040	200281	50-007-006
CATERPILLAR	D3		SALT	1.126	6.161	6.13	A3536	A3539	915082	200281	50-007-006
CATERPILLAR	D3	EARLY	SALT	1.126	6.161	6.13	A3536	A3539	915082	200281	50-007-006
CATERPILLAR	D3		SALT	1.126	6.161	6.13	A3536	A3539	915082	200281	50-007-006
CATERPILLAR	D3	FORMER	SALT	1.126	6.161	6.13	A3536	A3539	915082	200281	50-007-006
CATERPILLAR	D3		SEALED	1.129	6.156	6.13	A3536	A3539	915004	200281	50-007-006
CATERPILLAR	D3B		SALT	1.126	6.161	6.13	A3536	A3539	915082	200281	50-007-006
CATERPILLAR	D3B		SEALED	1.129	6.156	6.13	A3536	A3539	915004	200281	50-007-006
CATERPILLAR	D3C		SALT	1.126	6.161	6.13	A3536	A3539	915082	200281	50-007-006
CATERPILLAR	D3G		SALT	1.126	6.161	6.13	A3536	A3539	915082	200281	50-007-006
CATERPILLAR	D3G		SEALED	1.129	6.156	6.13	A3536	A3539	915004	200281	50-007-006
CATERPILLAR	D4		RECESS	1.314	7	6.74	A3537	A3540	915011	25499	50-007-005
CATERPILLAR	D4		SEALED	1.314	7	6.74	A3537	A3540	915002	25499	50-007-005
CATERPILLAR	D4		SALT	1.314	7.22	6.74	A3537	A3540	915052	25499	50-007-005
CATERPILLAR	D4	w/ 1/2 BOLT	SEALED	1.314	7	6.74	A3537	A3540	915137	25499	50-007-005
CATERPILLAR	D4	w/ 9/16 BOLT	SEALED	1.314	7	6.74	A3537	A3540	915137	25499	50-007-005
CATERPILLAR	D4	w/ 9/16 BOLT	SEALED	1.314	7	6.74	A3537	A3540	915138	25499	50-007-005



WTC Machinery FP250 Tooling Chart

6/9/2022

Make	Model	Comments	Type	Pin Dimensions			Disassembly Tools		Assembly Tools		
				Dia	Length	Pitch	Pin Tool	Back. Bush.	PAT (2)	Forcing Pin	Bushing
CATERPILLAR	D4B		SALT	1.126	6.161	6.13	A3536	A3539	915082	200281	50-007-006
CATERPILLAR	D4B		SEALED	1.129	6.156	6.13	A3536	A3539	915004	200281	50-007-006
CATERPILLAR	D4C		SALT	1.126	6.161	6.13	A3536	A3539	915082	200281	50-007-006
CATERPILLAR	D4C		SEALED	1.129	6.156	6.13	A3536	A3539	915004	200281	50-007-006
CATERPILLAR	D4C	w/ 1/2 BOLT	SEALED	1.314	7	6.74	A3537	A3540	915137	25499	50-007-005
CATERPILLAR	D4C	w/ 9/16 BOLT	SEALED	1.314	7	6.74	A3537	A3540	915137	25499	50-007-005
CATERPILLAR	D4C	w/ 9/16 BOLT	SEALED	1.314	7	6.74	A3537	A3540	915138	25499	50-007-005
CATERPILLAR	D4D		SALT	1.314	7.22	6.74	A3537	A3540	915052	25499	50-007-005
CATERPILLAR	D4D		SEALED	1.314	7	6.74	A3537	A3540	915002	25499	50-007-005
CATERPILLAR	D4D		SEALED	1.314	7.22	6.74	A3537	A3540	915011	25499	50-007-005
CATERPILLAR	D4D	w/ 1/2 BOLT	SEALED	1.314	7	6.74	A3537	A3540	915137	25499	50-007-005
CATERPILLAR	D4D	w/ 9/16 BOLT	SEALED	1.314	7	6.74	A3537	A3540	915137	25499	50-007-005
CATERPILLAR	D4D	w/ 9/16 BOLT	SEALED	1.314	7	6.74	A3537	A3540	915138	25499	50-007-005
CATERPILLAR	D4E		SALT	1.314	7.22	6.74	A3537	A3540	915052	25499	50-007-005
CATERPILLAR	D4G		SALT	1.126	6.161	6.13	A3536	A3539	915082	200281	50-007-006
CATERPILLAR	D4G		SEALED	1.129	6.156	6.13	A3536	A3539	915004	200281	50-007-006
CATERPILLAR	D4H	LGP	PPR	1.315	7.287	6.74	A3537	A3540		25499	50-007-005
CATERPILLAR	D4H		SALT	1.315	7.22	6.74	A3537	A3540	915124	25499	50-007-005
CATERPILLAR	D4H		SALT	1.318	7.535	6.74	A3537	A3540	915149	25499	50-007-005
CATERPILLAR	D4H	TSK CUS SKD	SALT	1.318	7.535	6.74	A3537	A3540	915149	25499	50-007-005
CATERPILLAR	D4H	HD	SALT	1.418	8.445	6.74	B3635	A3541	915145	25499	50-007-004
CATERPILLAR	D5	PRO	SALT	1.442	8.12	6.91	B3635	A3541	915052	25500	50-007-004
CATERPILLAR	D5		SALT	1.442	8.12	6.91	B3635	A3541	915018	25500	50-007-004
CATERPILLAR	D5		SEALED	1.442	8.125	6.91	B3635	A3541	915009	25500	50-007-004
CATERPILLAR	D5B		SALT	1.442	8.12	6.91	B3635	A3541	915052	25500	50-007-004
CATERPILLAR	D5B		SEALED	1.442	8.125	6.91	B3635	A3541	915009	25500	50-007-004
CATERPILLAR	D5C		SALT	1.318	7.535	6.74	A3537	A3540	915149	25499	50-007-005
CATERPILLAR	D5G		SALT	1.318	7.535	6.74	A3537	A3540	915149	25499	50-007-005
CATERPILLAR	D5G	XL	SALT	1.318	7.535	6.74	A3537	A3540	915149	25499	50-007-005
CATERPILLAR	D5H		SALT	1.443	8.122	7.48	B3635	A3541	915052	25500	50-007-004
CATERPILLAR	D5H	TSK CUS SKD	SALT	1.443	8.183	7.48	B3635	A3541	915052	25500	50-007-004
CATERPILLAR	D5H	HD	SALT	1.495	9.392	7.48	B3635	A3541	915145	25500-001	50-007-010
CATERPILLAR	D5M		SALT	1.418	8.445	6.74	B3635	A3541	915145	25499	50-007-004
CATERPILLAR	D5N		SALT	1.418	8.445	6.74	B3635	A3541	915145	25499	50-007-004
CATERPILLAR	D6		RECESS	1.442	8.125	6.74	B3635	A3541	915014	25500	50-007-004
CATERPILLAR	D6		SALT	1.752	9.06	7.98	B3635	A3541	915081	25548	50-007-002
CATERPILLAR	D6		SEALED	1.442	8.125	6.74	B3635	A3541	915009	25500	50-007-004
CATERPILLAR	D6B		SEALED	1.442	8.125	6.74	B3635	A3541	915009	25500	50-007-004
CATERPILLAR	D6C		SALT	1.753	9.06	7.98	B3635	A3541	915003	25548	50-007-002
CATERPILLAR	D6C		SEALED	1.252	9.06	7.98	A3537	A3540	915003	25498	50-007-005
CATERPILLAR	D6D		SALT	1.753	9.06	7.98	B3635	A3541	915003	25548	50-007-002
CATERPILLAR	D6D		SEALED	1.252	9.06	7.98	A3537	A3540	915003	25498	50-007-005
CATERPILLAR	D6E		SALT	1.753	9.06	7.98	B3635	A3541	915003	25548	50-007-002
CATERPILLAR	D6H	LGP	PPR	1.753	9.15	7.98	B3635	A3541	915143	25548	50-007-002
CATERPILLAR	D6H	LGP	SALT	1.753	9.06	7.98	B3635	A3541	915081	25548	50-007-002
CATERPILLAR	D6H		SALT	1.753	9.06	7.98	B3635	A3541	915081	25548	50-007-002
CATERPILLAR	D6H	HD	SALT	1.753	10.315	8.00	B3635	A3541	915143	25548	50-007-002
CATERPILLAR	D6M		SALT	1.495	9.392	7.48	B3635	A3541	915145	25500-001	50-007-010
CATERPILLAR	D6N		SALT	1.495	9.392	7.48	B3635	A3541	915145	25500-001	50-007-010
CATERPILLAR	D6R		SALT	1.753	10.315	8.00	B3635	A3541	915081	25548	50-007-002
CATERPILLAR	D7		RECESS	1.752	9.875	7.99	B3635	A3541	915012	25548	50-007-002
CATERPILLAR	D7		SALT	1.877	9.88	8.50	B3815	A3541	915006	25551	50-007-002
CATERPILLAR	D7		SEALED	1.752	9.875	7.98	B3635	A3541	915012	25548	50-007-002
CATERPILLAR	D7C		SEALED	1.752	9.875	7.98	B3635	A3541	915012	25548	50-007-002
CATERPILLAR	D7D		RECESS	1.752	9.875	7.99	B3635	A3541	915012	25548	50-007-002
CATERPILLAR	D7D		SEALED	1.752	9.875	7.98	B3635	A3541	915012	25548	50-007-002
CATERPILLAR	D7E		SALT	1.877	9.88	8.50	B3815	A3541	915006	25551	50-007-002
CATERPILLAR	D7E		SEALED	1.877	9.88	8.50	B3815	A3541	915012	25551	50-007-002
CATERPILLAR	D7F		SALT	1.877	9.88	8.50	B3815	A3541	915006	25551	50-007-002
CATERPILLAR	D7F		SEALED	1.877	9.88	8.50	B3815	A3541	915012	25551	50-007-002
CATERPILLAR	D7G		SALT	1.877	9.88	8.50	B3815	A3541	915006	25551	50-007-002
CATERPILLAR	D7G	LGP	SALT	1.877	9.88	8.50	B3815	A3541	915006	25551	50-007-002
CATERPILLAR	D7G		SEALED	1.877	9.88	8.50	B3815	A3541	915012	25551	50-007-002
CATERPILLAR	D7H	LGP	PPR	1.878	9.925	8.50	B3815	A3541	915007	25551	50-007-002
CATERPILLAR	D7H		SALT	1.878	9.88	8.50	B3815	A3541	915103	25551	50-007-002
CATERPILLAR	D7H	HD	SALT	1.878	10.875	8.50	B3815	A3541	915150	25551	50-007-002
CATERPILLAR	D7R		SALT	1.878	10.875	8.50	B3815	A3541	915150	25551	50-007-002
CATERPILLAR	D8		RECESS	1.752	11.438	7.95	B3635	A3541	915206	25548	50-007-002
CATERPILLAR	D8		SALT	2.002	11.438	9.00	B3815	A3541	915007	25501	50-007-001



WTC Machinery FP250 Tooling Chart

6/9/2022

Make	Model	Comments	Type	Pin Dimensions			Disassembly Tools		Assembly Tools		
				Dia	Length	Pitch	Pin Tool	Back. Bush.	PAT (2)	Forcing Pin	Bushing
CATERPILLAR	D8		SEALED	1.752	11.438	7.99	B3635	A3541	915013	25548	50-007-002
CATERPILLAR	D8D		SEALED	1.752	11.438	7.99	B3635	A3541	915013	25548	50-007-002
CATERPILLAR	D8E		SEALED	1.752	11.438	7.99	B3635	A3541	915013	25548	50-007-002
CATERPILLAR	D8F		SEALED	1.752	11.438	7.99	B3635	A3541	915013	25548	50-007-002
CATERPILLAR	D8G		SEALED	1.752	11.438	7.99	B3635	A3541	915013	25548	50-007-002
CATERPILLAR	D8H		SALT	2.002	11.438	9.00	B3815	A3541	915007	25501	50-007-001
CATERPILLAR	D8H		SEALED	2.003	11.438	9.00	B3815	A3541	915001	25501	50-007-001
CATERPILLAR	D8K		SALT	2.002	11.438	9.00	B3815	A3541	915007	25501	50-007-001
CATERPILLAR	D8K		SEALED	2.003	11.438	9.00	B3815	A3541	915001	25501	50-007-001
CATERPILLAR	D8L		SALT	1.88	9.88	8.50	B3815	A3541	915006	25551	50-007-002
CATERPILLAR	D8N		PPR	1.878	9.65	8.50	B3815	A3541	915207	25551	50-007-002
CATERPILLAR	D8N		SALT	1.88	9.88	8.50	B3815	A3541	915006	25551	50-007-002
CATERPILLAR	D8R		PPR	1.878	9.65	8.50	B3815	A3541	915207	25551	50-007-002
CATERPILLAR	D8R		SALT	1.88	9.88	8.50	B3815	A3541	915006	25551	50-007-002
CATERPILLAR	D8T		SALT	1.878	9.65	8.50	B3815	A3541	915006	25551	50-007-002
CATERPILLAR	D8T		SALT	1.88	9.88	8.50	B3815	A3541	915006	25551	50-007-002
CATERPILLAR	D9		SALT	2.252	12.25	10.25	B3607/8	A3541	915008	25553	50-021-2
CATERPILLAR	D9		SEALED	2.002	12	9.00	B3815	A3541	915208	25501	50-007-001
CATERPILLAR	D9D		SEALED	2.252	12.25	10.25	B3607/8	A3541	915005	25553	50-021-2
CATERPILLAR	D9E		SEALED	2.252	12.25	10.25	B3607/8	A3541	915005	25553	50-021-2
CATERPILLAR	D9G		SALT	2.252	12.25	10.25	B3607/8	A3541	915008	25553	50-021-2
CATERPILLAR	D9G		SEALED	2.252	12.25	10.25	B3607/8	A3541	915005	25553	50-021-2
CATERPILLAR	D9H		SALT	2.252	12.25	10.25	B3607/8	A3541	915008	25553	50-021-2
CATERPILLAR	D9H		SEALED	2.252	12.25	10.25	B3607/8	A3541	915005	25553	50-021-2
CATERPILLAR	D9L		PPR	2	10.77	9.00	B3815	A3541	915253	25501	50-007-001
CATERPILLAR	D9L		SALT	2	11.437	9.00	B3815	A3541	915093	25501	50-007-001
CATERPILLAR	D9N		PPR	2	10.44	9.45	B3815	A3541	915253	25501	50-007-001
CATERPILLAR	D9N		SALT	2.003	10.98	9.45	B3815	A3541	915092	25501	50-007-001
CATERPILLAR	D9R		PPR	2	10.44	9.45	B3815	A3541	915253	25501	50-007-001
CATERPILLAR	D9R		SALT	2.003	10.98	9.45	B3815	A3541	915092	25501	50-007-001
CATERPILLAR	E110B		SEALED	1.319	7.008	6.75	A3537	A3540	915059	25499	50-007-005
CATERPILLAR	E120B		SEALED	1.319	7.008	6.75	A3537	A3540	915059	25499	50-007-005
CATERPILLAR	E180		SEALED	1.439	8.126	6.91	B3635	A3541	915128	25500	50-007-004
CATERPILLAR	E200B		SEALED	1.445	8.15	7.50	B3635	A3541	915133	25500	50-007-004
CATERPILLAR	E240		SEALED	1.445	8.15	7.50	B3635	A3541	915133	25500	50-007-004
CATERPILLAR	E300B		SEALED	1.75	9.646	8.00	B3635	A3541	915121	25548	50-007-002
CATERPILLAR	E450		UNSEALED	1.873	10	8.50	B3815	A3541	915038	25551	50-007-002
CATERPILLAR	E70		SEALED	0.945	5.512	5.32	A3536	A3539	915129	200281	50-007-007
CATERPILLAR	EL180		SEALED	1.439	8.126	6.91	B3635	A3541	915128	25500	50-007-004
CATERPILLAR	EL200B		SEALED	1.445	8.15	7.50	B3635	A3541	915133	25500	50-007-004
CATERPILLAR	EL240		SEALED	1.445	8.15	7.50	B3635	A3541	915133	25500	50-007-004
CATERPILLAR	EL300A		SEALED	1.75	9.646	8.00	B3635	A3541	915121	25548	50-007-002
CATERPILLAR	EL300B		SEALED	1.75	9.646	8.00	B3635	A3541	915121	25548	50-007-002
CATERPILLAR	EL300B		SEALED	1.75	9.646	8.00	B3635	A3541	915038	25548	50-007-002
CATERPILLAR	FB227		SEALED	1.252	9.06	7.98	A3537	A3540	915003	25498	50-007-005
CATERPILLAR	MHI 180-8		SEALED	1.439	8.126	6.91	B3635	A3541	915128	25500	50-007-004
CATERPILLAR	MHI 180-8LC		SEALED	1.439	8.126	6.91	B3635	A3541	915128	25500	50-007-004
CATERPILLAR	MHI 300LC-8		SEALED	1.75	9.646	8.00	B3635	A3541	915121	25548	50-007-002
CATERPILLAR	PR450		SEALED	1.129	6.156	6.13	A3536	A3539	915004	200281	50-007-006
CATERPILLAR	R2-15-22		RECESS	1.127	6.156	6.13	A3536	A3539	916040	200281	50-007-006
CATERPILLAR	R4		RECESS	1.314	7	6.74	A3537	A3540	915011	25499	50-007-005
CATERPILLAR	SF350		SEALED	1.129	6.156	6.13	A3536	A3539	915004	200281	50-007-006
CATERPILLAR	TR225		SEALED	1.129	6.156	6.13	A3536	A3539	915004	200281	50-007-006
DRESSER	150		SEALED	1.375	6.69	6.49	B3635	A3541	915048	25499	50-007-004
DRESSER	175		SEALED	1.625	7.87	6.99	B3635	A3541	915041	25547	50-007-003
DRESSER	500		RECESSED	1.125	5.36	6.00	A3536	A3539	915044	200281	50-007-006
DRESSER	100B		SEALED	1.25	5.97	6.00	A3537	A3540	915034	25498	50-007-005
DRESSER	100C		SEALED	1.25	6.5	6.00	A3537	A3540	915040	25498	50-007-005
DRESSER	100E		SEALED	1.25	6.5	5.99	A3537	A3540	915100	25498	50-007-005
DRESSER	100G		SALT	1.312	6.69	6.49	A3537	A3540	915133	25499	50-007-005
DRESSER	125C		SEALED	1.375	6.69	6.49	B3635	A3541	915048	25499	50-007-004
DRESSER	125E		SEALED	1.375	6.69	6.49	B3635	A3541	915048	25499	50-007-004
DRESSER	125G		DRY	1.312	6.69	6.49	A3537	A3540	915213	25499	50-007-005
DRESSER	125G		SALT	1.312	6.69	6.49	A3537	A3540	915133	25499	50-007-005
DRESSER	125G		SEALED	1.312	6.69	6.49	A3537	A3540	915040	25499	50-007-005
DRESSER	175B		SEALED	1.625	7.87	6.99	B3635	A3541	915041	25547	50-007-003
DRESSER	175B		SEALED	1.75	8.81	7.50	B3635	A3541	915036	25548	50-007-002
DRESSER	175C		SEALED	1.75	8.81	7.50	B3635	A3541	915036	25548	50-007-002
DRESSER	250B		SEALED	1.75	9.31	7.50	B3635	A3541	915036	25548	50-007-002



WTC Machinery FP250 Tooling Chart

6/9/2022

Make	Model	Comments	Type	Pin Dimensions			Disassembly Tools		Assembly Tools		
				Dia	Length	Pitch	Pin Tool	Back. Bush.	PAT (2)	Forcing Pin	Bushing
DRESSER	250C		SEALED	1.75	9.31	7.50	B3635	A3541	915036	25548	50-007-002
DRESSER	500E		DRY	1.125	5.3	5.99	A3536	A3539	915209	200281	50-007-006
DRESSER	D32		SALT	1.312	6.69	6.49	A3537	A3540	915133	25499	50-007-005
DRESSER	D32E		SALT	1.312	6.69	6.49	A3537	A3540	915133	25499	50-007-005
DRESSER	D32E		SEALED	1.25	6.5	6.00	A3537	A3540	915040	25498	50-007-005
DRESSER	D32P		SEALED	1.25	6.5	6.00	A3537	A3540	915040	25498	50-007-005
DRESSER	D32-P1		SALT	1.312	6.69	6.49	A3537	A3540	915133	25499	50-007-005
DRESSER	D38E		SALT	1.312	6.69	6.49	A3537	A3540	915133	25499	50-007-005
DRESSER	D38P-1		SALT	1.312	6.69	6.49	A3537	A3540	915133	25499	50-007-005
DRESSER	D38P-1		SALT	1.312	6.69	6.49	A3537	A3540	915133	25499	50-007-005
DRESSER	D39		SALT	1.312	6.69	6.49	A3537	A3540	915133	25499	50-007-005
DRESSER	D39E		SALT	1.312	6.69	6.49	A3537	A3540	915133	25499	50-007-005
DRESSER	D87E-2		SALT	1.874	10.43	8.50	B3815	A3541	915077	25551	50-007-002
DRESSER	D87P		SALT	1.874	10.43	8.50	B3815	A3541	915077	25551	50-007-002
DRESSER	T340		FLUSH	1.01	4.75	6.00	A3536	A3539	915028	200281	50-007-007
DRESSER	T5		FLUSH	1.01	4.75	6.00	A3536	A3539	915028	200281	50-007-007
DRESSER	T6		SEALED	1.25	5.97	6.00	A3537	A3540	915034	25498	50-007-005
DRESSER	T7		SEALED	1.25	6.5	6.00	A3537	A3540	915040	25498	50-007-005
DRESSER	TD12		SALT	1.5	8.03	7.49	B3635	A3541	915095	25500	50-007-010
DRESSER	TD12		SEALED	1.75	8.03	7.49	B3635	A3541	915095	25548	50-007-002
DRESSER	TD12A		DRY	1.5	8.03	7.49	B3635	A3541	915210	25500	50-007-010
DRESSER	TD12B		DRY	1.5	8.03	7.49	B3635	A3541	915210	25500	50-007-010
DRESSER	TD12C		DRY	1.625	8.81	7.49	B3635	A3541	915211	25547L	50-007-003
DRESSER	TD12C-XP		SEALED	1.629	8.82	7.49	B3635	A3541	915083	25547L	50-007-003
DRESSER	TD14		SEALED	1.625	7.87	6.99	B3635	A3541	915041	25547	50-007-003
DRESSER	TD15		SEALED	1.625	7.87	6.99	B3635	A3541	915041	25547	50-007-003
DRESSER	TD15B		SEALED	1.625	7.87	6.99	B3635	A3541	915041	25547	50-007-003
DRESSER	TD15B		SEALED	1.75	8.81	7.50	B3635	A3541	915036	25548	50-007-002
DRESSER	TD15C	SPLIT	DRY	1.625	8.81	7.49	B3635	A3541	915211	25547L	50-007-003
DRESSER	TD15C		SALT	1.625	8.81	7.49	B3635	A3541	915021	25547L	50-007-003
DRESSER	TD15C	LGP	SALT	1.625	8.81	7.49	B3635	A3541	915021	25547L	50-007-003
DRESSER	TD15C	SPLIT	SEALED	1.625	8.81	7.49	B3635	A3541	915021	25547L	50-007-003
DRESSER	TD15C		SEALED	1.75	8.81	7.50	B3635	A3541	915036	25548	50-007-002
DRESSER	TD15E		SALT	1.75	8.81	7.98	B3635	A3541	915109	25548	50-007-002
DRESSER	TD15E	LGP	SALT	1.75	8.81	7.98	B3635	A3541	915109	25548	50-007-002
DRESSER	TD15E		SEALED	1.75	8.81	7.98	B3635	A3541	915108	25548	50-007-002
DRESSER	TD20B		SEALED	1.75	9.31	7.50	B3635	A3541	915036	25548	50-007-002
DRESSER	TD20C		SEALED	1.75	9.31	7.50	B3635	A3541	915036	25548	50-007-002
DRESSER	TD20C		SEALED	1.875	9.31	8.50	B3815	A3541	915035	25551	50-007-002
DRESSER	TD20E		DRY	1.874	10.43	8.50	B3815	A3541	915212	25551	50-007-002
DRESSER	TD20E		SALT	1.874	10.43	8.50	B3815	A3541	915077	25551	50-007-002
DRESSER	TD20E	SPLIT	SEALED	1.875	10.43	8.50	B3815	A3541	915077	25551	50-007-002
DRESSER	TD20E		SEALED	1.875	10.44	8.50	B3815	A3541	915038	25551	50-007-002
DRESSER	TD20G		DRY	1.874	10.43	8.50	B3815	A3541	915212	25551	50-007-002
DRESSER	TD20G		SALT	1.874	10.43	8.50	B3815	A3541	915077	25551	50-007-002
DRESSER	TD20G	LGP	SALT	1.874	10.43	8.50	B3815	A3541	915077	25551	50-007-002
DRESSER	TD24		SEALED	1.875	11	8.50	B3815	A3541	915037	25551	50-007-002
DRESSER	TD25B		SEALED	1.875	11	8.50	B3815	A3541	915037	25551	50-007-002
DRESSER	TD25C		SALT	2.125	11	9.86	B3607/8	A3541	915102	25501	50-007-001
DRESSER	TD25C		SALT	2.125	11	9.87	B3607/8	A3541	915102	25501	50-007-001
DRESSER	TD25C		SEALED	2.125	11	9.87	B3607/8	A3541	915102	25501	50-007-001
DRESSER	TD25E		SALT	2.125	11	9.86	B3607/8	A3541	915102	25501	50-007-001
DRESSER	TD25E		SALT	2.125	11	9.87	B3607/8	A3541	915102	25501	50-007-001
DRESSER	TD25E		SEALED	2.125	11	9.87	B3607/8	A3541	915102	25501	50-007-001
DRESSER	TD25E	SPLIT	SEALED	2.125	11	9.87	B3607/8	A3541	915102	25501	50-007-001
DRESSER	TD25G		DRY	2.125	11	9.86	B3607/8	A3541	915102	25501	50-007-001
DRESSER	TD25G		SALT	2.125	11	9.87	B3607/8	A3541	915102	25501	50-007-001
DRESSER	TD30		SALT	2.125	11	9.86	B3607/8	A3541	915102	25501	50-007-001
DRESSER	TD30		SEALED	2.125	11	9.87	B3607/8	A3541	915102	25501	50-007-001
DRESSER	TD4		FLUSH	1.01	4.75	6.00	A3536	A3539	915028	200281	50-007-007
DRESSER	TD40	SPLIT	SALT	2.456	12.6	11.02	B3607/8	A3541	915101	25553L	50-021-2
DRESSER	TD40	SPLIT	SEALED	2.456	12.6	11.02	B3607/8	A3541	915101	25553L	50-021-2
DRESSER	TD5		FLUSH	1.01	4.75	6.00	A3536	A3539	915028	200281	50-007-007
DRESSER	TD6		SEALED	1.25	5.97	6.00	A3537	A3540	915034	25498	50-007-005
DRESSER	TD7		SEALED	1.25	6.5	6.00	A3537	A3540	915040	25498	50-007-005
DRESSER	TD7C		SEALED	1.25	6.5	6.00	A3537	A3540	915040	25498	50-007-005
DRESSER	TD7E		SEALED	1.25	6.5	5.99	A3537	A3540	915100	25498	50-007-005
DRESSER	TD7G		SALT	1.312	6.69	6.49	A3537	A3540	915133	25499	50-007-005
DRESSER	TD7H		DRY	1.312	6.69	6.49	A3537	A3540	915213	25499	50-007-005



WTC Machinery FP250 Tooling Chart

6/9/2022

Make	Model	Comments	Type	Pin Dimensions			Disassembly Tools		Assembly Tools		
				Dia	Length	Pitch	Pin Tool	Back. Bush.	PAT (2)	Forcing Pin	Bushing
DRESSER	TD8C		SEALED	1.375	6.69	6.49	B3635	A3541	915048	25499	50-007-004
DRESSER	TD8E		SEALED	1.375	6.69	6.49	B3635	A3541	915048	25499	50-007-004
DRESSER	TD8G		SALT	1.312	6.69	6.49	A3537	A3540	915133	25499	50-007-005
DRESSER	TD8G		SEALED	1.312	6.69	6.49	A3537	A3540	915040	25499	50-007-005
DRESSER	TD-8G		DRY	1.312	6.69	6.49	A3537	A3540	915213	25499	50-007-005
DRESSER	TD9B		SEALED	1.375	6.69	6.49	B3635	A3541	915048	25499	50-007-004
DRESSER	TD9H		SALT	1.312	6.69	6.49	A3537	A3540	915133	25499	50-007-005
FIAT	31		DRY	2.374	12.953	11.28	B3607/8	A3541	915142	25553L	50-021-2
FIAT	31		SALT	2.374	12.953	11.28	B3607/8	A3541	915221	25553L	50-021-2
FIAT	652		UNSEALED	1.25	6.24	6.00	A3537	A3540	915004	25498	50-007-005
FIAT	653		UNSEALED	1.25	6.24	6.00	A3537	A3540	915004	25498	50-007-005
FIAT	655		UNSEALED	1.25	6.24	6.00	A3537	A3540	915004	25498	50-007-005
FIAT	12G		SEALED	1.876	10.27	7.85	B3815	A3541	915020	25551	50-007-002
FIAT	12G		UNSEALED	1.874	10.27	7.86	B3815	A3541	915020	25551	50-007-002
FIAT	12GB		SEALED	1.878	10.27	7.86	B3815	A3541	915030	25551	50-007-002
FIAT	14B		UNSEALED	1.578	8.661	7.48	B3635	A3541	915022	25547L	50-007-010
FIAT	41B		DRY	2.622	14	11.28	B3631/2	A6212	915218	25553L	50-021-3
FIAT	41B		SALT	2.622	14	11.28	B3631/2	A6212	915218	25553L	50-021-3
FIAT	AD10		UNSEALED	1.459	7.874	6.93	B3635	A3541	915022	25500	50-007-004
FIAT	AD10B		UNSEALED	1.459	7.874	6.93	B3635	A3541	915022	25500	50-007-004
FIAT	AD12		SALT	1.577	8.66	6.00	B3635	A3541	915022	25547L	50-007-010
FIAT	AD12		UNSEALED	1.578	8.661	7.48	B3635	A3541	915022	25547L	50-007-010
FIAT	AD14		SALT	1.577	8.66	6.00	B3635	A3541	915022	25547L	50-007-010
FIAT	AD14		UNSEALED	1.578	8.661	7.48	B3635	A3541	915022	25547L	50-007-010
FIAT	AD18		UNSEALED	1.87	9.84	8.50	B3815	A3541	915019	25551	50-007-002
FIAT	AD20		UNSEALED	1.87	9.84	8.50	B3815	A3541	915019	25551	50-007-002
FIAT	AD4		UNSEALED	0.984	5.28	5.51	A3536	A3539	915028	200281	50-007-007
FIAT	AD5		UNSEALED	1.181	6.1	6.30	A3536	A3539	915027	25498	50-007-006
FIAT	AD6		UNSEALED	1.377	7.01	6.69	B3635	A3541	915025	25499	50-007-004
FIAT	AD7		UNSEALED	1.377	7.01	6.69	B3635	A3541	915025	25499	50-007-004
FIAT	AD7C		UNSEALED	1.377	7.01	6.69	B3635	A3541	915025	25499	50-007-004
FIAT	AD8		UNSEALED	1.38	7.126	6.69	B3635	A3541	915025	25499	50-007-004
FIAT	AD9		UNSEALED	1.377	7.01	6.69	B3635	A3541	915025	25499	50-007-004
FIAT	B1		UNSEALED	0.984	5.28	5.51	A3536	A3539	915028	200281	50-007-007
FIAT	BD10		UNSEALED	1.459	7.874	6.93	B3635	A3541	915022	25500	50-007-004
FIAT	BD10B		UNSEALED	1.459	7.874	6.93	B3635	A3541	915022	25500	50-007-004
FIAT	BD12		SALT	1.577	8.66	6.00	B3635	A3541	915022	25547L	50-007-010
FIAT	BD12		UNSEALED	1.578	8.661	7.48	B3635	A3541	915022	25547L	50-007-010
FIAT	BD14		SALT	1.577	8.66	6.00	B3635	A3541	915022	25547L	50-007-010
FIAT	BD14		UNSEALED	1.578	8.661	7.48	B3635	A3541	915022	25547L	50-007-010
FIAT	BD18		UNSEALED	1.87	9.84	8.50	B3815	A3541	915019	25551	50-007-002
FIAT	BD20		UNSEALED	1.87	9.84	8.50	B3815	A3541	915019	25551	50-007-002
FIAT	BD7		UNSEALED	1.377	7.01	6.69	B3635	A3541	915025	25499	50-007-004
FIAT	BD7C		UNSEALED	1.377	7.01	6.69	B3635	A3541	915025	25499	50-007-004
FIAT	BD8		UNSEALED	1.38	7.126	6.69	B3635	A3541	915025	25499	50-007-004
FIAT	BD9		UNSEALED	1.377	7.01	6.69	B3635	A3541	915025	25499	50-007-004
FIAT	F318		SEALED	1.377	7.165	6.69	B3635	A3541	915154	25499	50-007-004
FIAT	FA200		SALT	1.577	8.66	6.00	B3635	A3541	915022	25547L	50-007-010
FIAT	FD14		SALT	1.577	8.66	6.00	B3635	A3541	915022	25547L	50-007-010
FIAT	FD20		SALT	1.88	9.9	8.50	B3815	A3541	915006	25551	50-007-002
FIAT	FD20		UNSEALED	1.873	9.843	8.50	B3815	A3541	915019	25551	50-007-002
FIAT	FD30		SALT	2.036	11.65	9.04	B3815	A3541	915105	25501	50-007-001
FIAT	FD30		UNSEALED	2.036	11.66	9.04	B3815	A3541	915016	25501	50-007-001
FIAT	FD31		SALT	2.373	12.95	11.28	B3607/8	A3541	915094	25553L	50-021-2
FIAT	FD31		SEALED	2.373	12.95	11.25	B3607/8	A3541	915029	25553L	50-021-2
FIAT	FD31		UNSEALED	2.375	12.95	11.25	B3607/8	A3541	915073	25553L	50-021-2
FIAT	FD40		DRY	2.374	12.953	11.28	B3607/8	A3541	915142	25553L	50-021-2
FIAT	FD40		SALT	2.373	12.95	11.28	B3607/8	A3541	915094	25553L	50-021-2
FIAT	FD40		SALT	2.374	12.953	11.28	B3607/8	A3541	915221	25553L	50-021-2
FIAT	FD40		UNSEALED	2.375	12.95	11.25	B3607/8	A3541	915073	25553L	50-021-2
FIAT	FD40B		DRY	2.374	12.953	11.28	B3607/8	A3541	915142	25553L	50-021-2
FIAT	FD40B		SALT	2.374	12.953	11.28	B3607/8	A3541	915221	25553L	50-021-2
FIAT	FD5		SALT	1.26	6.42	6.30	A3537	A3540	915130	25498	50-007-005
FIAT	FD5		UNSEALED	1.143	6.457	6.30	A3536	A3539	915120	200281	50-007-006
FIAT	FD50		DRY	2.622	14	11.28	B3631/2	A6212	915218	25553L	50-021-3
FIAT	FD50		SALT	2.622	14	11.28	B3631/2	A6212	915218	25553L	50-021-3
FIAT	FD7		SALT	1.26	6.42	6.30	A3537	A3540	915130	25498	50-007-005
FIAT	FD7		UNSEALED	1.143	6.457	6.30	A3536	A3539	915120	200281	50-007-006
FIAT	FD9		SALT	1.382	7.17	6.69	B3635	A3541	915014	25499	50-007-004



WTC Machinery FP250 Tooling Chart

6/9/2022

Make	Model	Comments	Type	Pin Dimensions			Disassembly Tools		Assembly Tools		
				Dia	Length	Pitch	Pin Tool	Back. Bush.	PAT (2)	Forcing Pin	Bushing
FIAT	FD9		UNSEALED	1.382	7.17	6.69	B3635	A3541	915014	25499	50-007-004
FIAT	FE16		SEALED	1.377	7.165	6.69	B3635	A3541	915154	25499	50-007-004
FIAT	FE20		SEALED	1.377	7.165	6.69	B3635	A3541	915154	25499	50-007-004
FIAT	FE20LC		SEALED	1.377	7.165	6.69	B3635	A3541	915154	25499	50-007-004
FIAT	FE8LC		SEALED	1.377	7.165	6.69	B3635	A3541	915154	25499	50-007-004
FIAT	FH120		SEALED	1.377	7.165	6.69	B3635	A3541	915154	25499	50-007-004
FIAT	FH150		SEALED	1.377	7.165	6.69	B3635	A3541	915154	25499	50-007-004
FIAT	FH150LC		SEALED	1.377	7.165	6.69	B3635	A3541	915154	25499	50-007-004
FIAT	FH200		SEALED	1.458	8.031	6.93	B3635	A3541	915118	25500	50-007-004
FIAT	FH200LC		SEALED	1.458	8.031	6.93	B3635	A3541	915118	25500	50-007-004
FIAT	FL10		UNSEALED	1.459	7.874	6.93	B3635	A3541	915022	25500	50-007-004
FIAT	FL10B		UNSEALED	1.459	7.874	6.93	B3635	A3541	915022	25500	50-007-004
FIAT	FL12		UNSEALED	1.578	8.661	7.48	B3635	A3541	915022	25547L	50-007-010
FIAT	FL14		SALT	1.577	8.66	6.00	B3635	A3541	915022	25547L	50-007-010
FIAT	FL14		UNSEALED	1.578	8.661	7.48	B3635	A3541	915022	25547L	50-007-010
FIAT	FL14B		UNSEALED	1.578	8.661	7.48	B3635	A3541	915022	25547L	50-007-010
FIAT	FL14C		UNSEALED	1.578	8.661	7.48	B3635	A3541	915022	25547L	50-007-010
FIAT	FL14D		SALT	1.577	8.66	6.00	B3635	A3541	915022	25547L	50-007-010
FIAT	FL14E		SALT	1.577	8.66	6.00	B3635	A3541	915022	25547L	50-007-010
FIAT	FL20	S/N 7607 & DN	UNSEALED	1.873	9.843	8.50	B3815	A3541	915019	25551	50-007-002
FIAT	FL20	7608 & UP	SALT	1.88	9.9	8.50	B3815	A3541	915006	25551	50-007-002
FIAT	FL4AC		UNSEALED	0.984	5.28	5.51	A3536	A3539	915028	200281	50-007-007
FIAT	FL4AD		UNSEALED	0.984	5.28	5.51	A3536	A3539	915028	200281	50-007-007
FIAT	FL4L		UNSEALED	0.984	5.28	5.51	A3536	A3539	915028	200281	50-007-007
FIAT	FL5		SALT	1.26	6.42	6.30	A3537	A3540	915130	25498	50-007-005
FIAT	FL5		UNSEALED	1.143	6.457	6.30	A3536	A3539	915120	200281	50-007-006
FIAT	FL5B		SALT	1.26	6.42	6.30	A3537	A3540	915130	25498	50-007-005
FIAT	FL6		UNSEALED	1.181	6.1	6.30	A3536	A3539	915027	25498	50-007-006
FIAT	FL7		SALT	1.26	6.42	6.30	A3537	A3540	915130	25498	50-007-005
FIAT	FL7		UNSEALED	1.143	6.457	6.30	A3536	A3539	915120	200281	50-007-006
FIAT	FL7		UNSEALED	1.377	7.01	6.69	B3635	A3541	915025	25499	50-007-004
FIAT	FL7B		SALT	1.26	6.42	6.30	A3537	A3540	915130	25498	50-007-005
FIAT	FL8		UNSEALED	1.377	7.01	6.69	B3635	A3541	915025	25499	50-007-004
FIAT	FL8C		UNSEALED	1.377	7.01	6.69	B3635	A3541	915025	25499	50-007-004
FIAT	FL9		UNSEALED	1.38	7.126	6.69	B3635	A3541	915025	25499	50-007-004
FIAT	FP120	S/N 41-3000	DRY	2.374	12.953	11.28	B3607/8	A3541	915142	25553L	50-021-2
FIAT	FP120	S/N 41-3000	SALT	2.374	12.953	11.28	B3607/8	A3541	915221	25553L	50-021-2
FIAT	GH11E	S/N 10000 & DN	UNSEALED	1.565	8.14	7.00	B3635	A3541	915214	25547	50-007-010
FIAT	H3			1.253	5.84	6.00	A3537	A3540	915219	25498	50-007-005
FIAT	H4		UNSEALED	1.25	6.24	6.00	A3537	A3540	915004	25498	50-007-005
FIAT	H4			1.253	5.84	6.00	A3537	A3540	915219	25498	50-007-005
FIAT	HD10			1.753	8.37	7.85	B3635	A3541	915220	25548	50-007-002
FIAT	HD11	S/N 7538-10000	SEALED	1.562	8.14	7.00	B3635	A3541	915031	25547	50-007-010
FIAT	HD11	SN 5901 & UP	SEALED	1.62	8.4	7.01	B3635	A3541	915024	25547	50-007-003
FIAT	HD11	S/N 1000 & DN	UNSEALED	1.565	8.14	7.01	B3635	A3541	915023	25547	50-007-010
FIAT	HD11	S/N 10001 & UP	UNSEALED	1.62	8.4	7.01	B3635	A3541	915024	25547	50-007-003
FIAT	HD11B		SEALED	1.62	8.4	7.01	B3635	A3541	915024	25547	50-007-003
FIAT	HD11B	S/N 10001-19484	UNSEALED	1.62	8.4	7.01	B3635	A3541	915024	25547	50-007-003
FIAT	HD11B	S/N 19485 & UP	UNSEALED	1.62	8.6	7.01	B3635	A3541	915215	25547L	50-007-003
FIAT	HD11E	S/N 10000 & DN	SEALED	1.565	8.14	7.01	B3635	A3541	915023	25547	50-007-010
FIAT	HD11G	S/N 8940 & DN	SEALED	1.565	8.14	7.01	B3635	A3541	915023	25547	50-007-010
FIAT	HD11G	S/N 8940 & DN	UNSEALED	1.565	8.14	7.00	B3635	A3541	915214	25547	50-007-010
FIAT	HD11G	S/N 8940 & UP	UNSEALED	1.565	8.14	7.01	B3635	A3541	915023	25547	50-007-010
FIAT	HD14			1.875	9.67	7.85	B3815	A3541	915020	25551	50-007-002
FIAT	HD14			1.878	9.67	7.85	B3815	A3541	915216	25551	50-007-002
FIAT	HD15		UNSEALED	1.753	9.33	7.86	B3635	A3541	915021	25548	50-007-002
FIAT	HD16	S/N 5901 & UP	SEALED	1.876	10.27	7.85	B3815	A3541	915020	25551	50-007-002
FIAT	HD16	S/N 5900 & DN	UNSEALED	1.753	9.33	7.86	B3635	A3541	915021	25548	50-007-002
FIAT	HD16	S/N 5901 & UP	UNSEALED	1.874	10.27	7.86	B3815	A3541	915020	25551	50-007-002
FIAT	HD16B		SEALED	1.878	10.27	7.86	B3815	A3541	915030	25551	50-007-002
FIAT	HD19		SEALED	1.876	11.66	9.00	B3815	A3541	915017	25551	50-007-002
FIAT	HD19		SEALED	1.878	11.66	9.01	B3815	A3541	915017	25551	50-007-002
FIAT	HD19		UNSEALED	1.876	11.66	9.00	B3815	A3541	915217	25551	50-007-002
FIAT	HD20		SEALED	1.876	11.66	9.00	B3815	A3541	915017	25551	50-007-002
FIAT	HD20		SEALED	1.878	11.66	9.01	B3815	A3541	915017	25551	50-007-002
FIAT	HD20		UNSEALED	1.876	11.66	9.00	B3815	A3541	915217	25551	50-007-002
FIAT	HD21	S/N 13871-14942	SEALED	1.878	11.66	9.01	B3815	A3541	915017	25551	50-007-002
FIAT	HD21		UNSEALED	1.878	11.66	9.01	B3815	A3541	915017	25551	50-007-002
FIAT	HD21	S/N14943 & UP	SEALED	1.878	11.66	9.01	B3815	A3541	915017	25551	50-007-002



WTC Machinery FP250 Tooling Chart

6/9/2022

Make	Model	Comments	Type	Pin Dimensions			Disassembly Tools		Assembly Tools		
				Dia	Length	Pitch	Pin Tool	Back. Bush.	PAT (2)	Forcing Pin	Bushing
FIAT	HD21	S/N 14942 & DN	UNSEALED	1.878	11.66	9.01	B3815	A3541	915221	25551	50-007-002
FIAT	HD21B		SEALED	1.876	11.66	9.00	B3815	A3541	915016	25551	50-007-002
FIAT	HD21B		UNSEALED	1.876	11.66	9.00	B3815	A3541	915018	25551	50-007-002
FIAT	HD21C		UNSEALED	2.036	11.66	9.04	B3815	A3541	915016	25501	50-007-001
FIAT	HD21P	S/N 14942 & DN	SEALED	1.876	11.66	9.00	B3815	A3541	915017	25551	50-007-002
FIAT	HD21P	S/N 14942 & DN	UNSEALED	1.876	11.66	9.00	B3815	A3541	915217	25551	50-007-002
FIAT	HD21P	S/N 14943 & UP	UNSEALED	1.878	11.66	9.01	B3815	A3541	915017	25551	50-007-002
FIAT	HD3			1.253	5.84	6.00	A3537	A3540	915219	25498	50-007-005
FIAT	HD31		SALT	2.373	12.95	11.28	B3607/8	A3541	915094	25553L	50-021-2
FIAT	HD31		UNSEALED	2.375	12.95	11.25	B3607/8	A3541	915073	25553L	50-021-2
FIAT	HD4	S/N 3001 & UP	UNSEALED	1.25	6.24	6.00	A3537	A3540	915004	25498	50-007-005
FIAT	HD4			1.253	5.84	6.00	A3537	A3540	915219	25498	50-007-005
FIAT	HD41		SALT	2.373	12.95	11.28	B3607/8	A3541	915094	25553L	50-021-2
FIAT	HD41		SEALED	2.373	12.95	11.25	B3607/8	A3541	915029	25553L	50-021-2
FIAT	HD41		UNSEALED	2.375	12.95	11.25	B3607/8	A3541	915073	25553L	50-021-2
FIAT	HD41B		SALT	2.622	14	11.28	B3631/2	A6212	915218	25553L	50-021-3
FIAT	HD41B		UNSEALED	2.623	14	11.28	B3631/2	A6212	915033	25553L	50-021-3
FIAT	HD5		SEALED	1.375	6.91	6.50	B3635	A3541	915014	25499	50-007-004
FIAT	HD5		UNSEALED	1.375	6.91	6.50	B3635	A3541	915014	25499	50-007-004
FIAT	HD5			1.753	8.37	7.85	B3635	A3541	915220	25548	50-007-002
FIAT	HD50		SALT	2.622	14	11.28	B3631/2	A6212	915218	25553L	50-021-3
FIAT	HD50		UNSEALED	2.623	14	11.28	B3631/2	A6212	915033	25553L	50-021-3
FIAT	HD50			1.753	8.37	7.85	B3635	A3541	915220	25548	50-007-002
FIAT	HD6		SEALED	1.375	6.91	6.50	B3635	A3541	915014	25499	50-007-004
FIAT	HD6		UNSEALED	1.375	6.91	6.50	B3635	A3541	915014	25499	50-007-004
FIAT	HD7	S/N 1102 & DN	UNSEALED	1.738	7.51	6.50	B3635	A3541	915026	25548	50-007-002
FIAT	HD7	S/N 1103 & UP	UNSEALED	1.565	8.14	6.50	B3635	A3541	915023	25547	50-007-010
FIAT	HD7G		SEALED	1.565	8.14	7.01	B3635	A3541	915023	25547	50-007-010
FIAT	HD7G		UNSEALED	1.565	8.14	7.00	B3635	A3541	915214	25547	50-007-010
FIAT	HD7G		UNSEALED	1.565	8.14	7.01	B3635	A3541	915023	25547	50-007-010
FIAT	HD7G-B		SEALED	1.562	8.14	7.00	B3635	A3541	915031	25547	50-007-010
FIAT	HD9		SEALED	1.565	8.14	7.01	B3635	A3541	915023	25547	50-007-010
FIAT	HD9		UNSEALED	1.565	8.14	7.00	B3635	A3541	915214	25547	50-007-010
FIAT	HD9		UNSEALED	1.565	8.14	7.01	B3635	A3541	915023	25547	50-007-010
FIAT	K		UNSEALED	1.738	7.51	6.50	B3635	A3541	915026	25548	50-007-002
FIAT	KO		UNSEALED	1.738	7.51	6.50	B3635	A3541	915026	25548	50-007-002
FIAT	PH130		SEALED	1.377	7.165	6.69	B3635	A3541	915154	25499	50-007-004
FIAT	S11		SEALED	1.377	7.165	6.69	B3635	A3541	915154	25499	50-007-004
FIAT	S9		SEALED	1.377	7.165	6.69	B3635	A3541	915154	25499	50-007-004
FIAT	SL11	33/281 & UP	SEALED	1.377	7.165	6.69	B3635	A3541	915154	25499	50-007-004
FIAT	SL9	30/241 & UP	SEALED	1.377	7.165	6.69	B3635	A3541	915154	25499	50-007-004
HITACHI	EX100		UNSEALED	1.315	7.283	6.74	A3537	A3540	915223	25499	50-007-005
HITACHI	EX1100		SEALED	2.29	12.578	10.25	B3607/8	A3541	915171	25553L	50-021-2
HITACHI	EX120		UNSEALED	1.315	7.283	6.74	A3537	A3540	915223	25499	50-007-005
HITACHI	EX1200-5		SEALED	2.29	12.578	10.25	B3607/8	A3541	915171	25553L	50-021-2
HITACHI	EX150		SEALED	1.378	7.598	6.75	B3635	A3541	915002	25499	50-007-004
HITACHI	EX1800		SEALED	2.756	14.45	12.50	B3605/6	A6212	915107	25553L	50-021-4
HITACHI	EX200		SEALED	1.442	8.346	7.48	B3635	A3541	915134	25500	50-007-004
HITACHI	EX220		SEALED	1.496	8.346	7.48	B3635	A3541	915042	25500	50-007-010
HITACHI	EX300		SEALED	1.75	9.65	8.00	B3635	A3541	915121	25548	50-007-002
HITACHI	EX400		SEALED	1.875	10	8.50	B3815	A3541	915012	25551	50-007-002
HITACHI	EX550		SEALED	1.909	11.57	9.00	B3815	A3541	915087	25551	50-007-002
HITACHI	EX700		SEALED	2.185	12.61	10.25	B3607/8	A3541	915125	25501L	50-007-001
HITACHI	EX800		SEALED	2.185	12.61	10.25	B3607/8	A3541	915125	25501L	50-007-001
HITACHI	EX90		UNSEALED	1.315	7.283	6.74	A3537	A3540	915223	25499	50-007-005
HITACHI	UH083		SALT	1.44	8.11	6.91	B3635	A3541	915042	25500	50-007-004
HITACHI	UH801		SALT	2.756	14.37	12.50	B3605/6	A6212	915090	25553L	50-021-4
HITACHI	ZX350		SEALED	1.75	9.65	8.00	B3635	A3541	915121	25548	50-007-002
JCB	JS220		SALT	1.752	9.93	8.00	B3635	A3541	915084	25548	50-007-002
JCB	JS300		SALT	1.752	9.93	8.00	B3635	A3541	915084	25548	50-007-002
JCB	JS330		SALT	1.752	9.93	8.00	B3635	A3541	915084	25548	50-007-002
JCB	JS360		SALT	1.752	9.93	8.00	B3635	A3541	915084	25548	50-007-002
JOHN DEERE	50		SEALED	0.867	4.84	5.32	A3536	A3539	915027	200281	50-007-008
JOHN DEERE	70		SEALED	1.19	6.102	6.06	A3536	A3539	915025	25498	50-007-006
JOHN DEERE	80		SEALED	0.95	5.157	6.06	A3536	A3539	915074	200281	50-007-007
JOHN DEERE	110		SEALED	1.319	7.008	6.75	A3537	A3540	915002	25499	50-007-005
JOHN DEERE	120		SEALED	1.319	7.008	6.75	A3537	A3540	915002	25499	50-007-005
JOHN DEERE	135		SEALED	1.319	7.008	6.75	A3537	A3540	915002	25499	50-007-005
JOHN DEERE	350		FLUSH	1.192	5.47	5.75	A3536	A3539	915065	25498	50-007-006



WTC Machinery FP250 Tooling Chart

6/9/2022

Make	Model	Comments	Type	Pin Dimensions			Disassembly Tools		Assembly Tools		
				Dia	Length	Pitch	Pin Tool	Back. Bush.	PAT (2)	Forcing Pin	Bushing
JOHN DEERE	370		SEALED	1.873	10	8.50	B3815	A3541	915087	25551	50-007-002
JOHN DEERE	440		FLUSH	1.004	5.46875	5.75	A3536	A3539	915064	200281	50-007-007
JOHN DEERE	450		FLUSH	1.3765	6.08	6.29	B3635	A3541	915056	25499	50-007-004
JOHN DEERE	450		RECESSED	1.376	6.08	6.29	B3635	A3541	915056	25499	50-007-004
JOHN DEERE	490		RECESSED	1.32	6.97	6.75	A3537	A3540	915074	25499	50-007-005
JOHN DEERE	550		SEALED	1.376	6.2	6.29	B3635	A3541	915074	25499	50-007-004
JOHN DEERE	555		SEALED	1.376	6.2	6.29	B3635	A3541	915074	25499	50-007-004
JOHN DEERE	590	S/N 001787 & UP		1.366	7.598	6.75	A3537	A3540	915228	25499	50-007-004
JOHN DEERE	655		SALT	1.44	8.11	6.99	B3635	A3541	915042	25500	50-007-004
JOHN DEERE	655		SEALED	1.44	8.11	6.91	B3635	A3541	915042	25500	50-007-004
JOHN DEERE	700		SALT	1.44	8.11	6.99	B3635	A3541	915042	25500	50-007-004
JOHN DEERE	750		SALT	1.44	8.11	6.99	B3635	A3541	915042	25500	50-007-004
JOHN DEERE	750		SEALED	1.44	8.11	6.91	B3635	A3541	915042	25500	50-007-004
JOHN DEERE	755		SALT	1.44	8.11	6.99	B3635	A3541	915042	25500	50-007-004
JOHN DEERE	755		SEALED	1.44	8.11	6.91	B3635	A3541	915042	25500	50-007-004
JOHN DEERE	790		SEALED	1.496	8.58	7.48	B3635	A3541	915022	25500	50-007-010
JOHN DEERE	792		SEALED	1.75	9.646	8.00	B3635	A3541	915121	25548	50-007-002
JOHN DEERE	850		SEALED	1.75	9.06	8.00	B3635	A3541	915013	25548	50-007-002
JOHN DEERE	855		SALT	1.881	9.882	8.50	B3815	A3541	915006	25551	50-007-002
JOHN DEERE	855		SEALED	1.878	9.902	8.50	B3815	A3541	915083	25551	50-007-002
JOHN DEERE	890		RECESSED	1.88	9.9	8.50	B3815	A3541	915227	25551	50-007-002
JOHN DEERE	890		SEALED	1.878	9.902	8.50	B3815	A3541	915083	25551	50-007-002
JOHN DEERE	990		SEALED	1.878	9.902	8.50	B3815	A3541	915083	25551	50-007-002
JOHN DEERE	1280	EXC		1.439	8.11	6.90	B3635	A3541	915229	25500	50-007-004
JOHN DEERE	2010	S/N 42000 & DN	FLUSH	1.004	5.46875	5.75	A3536	A3539	915064	200281	50-007-007
JOHN DEERE	2010	S/N 42001 & UP	FLUSH	1.192	5.47	5.75	A3536	A3539	915065	25498	50-007-006
JOHN DEERE	1050C			2	10.31	8.50	B3815	A3541	915172	25501	50-007-001
JOHN DEERE	1050J			2	10.31	8.50	B3815	A3541	915172	25501	50-007-001
JOHN DEERE	1150D		SALT	1.44	8.11	6.68	B3635	A3541	915215	25500	50-007-004
JOHN DEERE	1155D		SALT	1.44	8.11	6.68	B3635	A3541	915215	25500	50-007-004
JOHN DEERE	120 EXC		SEALED	1.3	7.24	6.96	A3537	A3540	915059	25499	50-007-005
JOHN DEERE	120C		SEALED	1.319	7.008	6.75	A3537	A3540	915002	25499	50-007-005
JOHN DEERE	160LC		SEALED	1.493	8.366	7.48	B3635	A3541	915042	25500	50-007-010
JOHN DEERE	190E		SEALED	1.19	6.102	6.06	A3536	A3539	915025	25498	50-007-006
JOHN DEERE	190E			1.19	6.102	6.06	A3536	A3539	915230	25498	50-007-006
JOHN DEERE	200LC		SEALED	1.493	8.366	7.48	B3635	A3541	915042	25500	50-007-010
JOHN DEERE	230		SEALED	1.493	8.366	7.48	B3635	A3541	915042	25500	50-007-010
JOHN DEERE	230CLC		SEALED	1.496	8.583	7.48	B3635	A3541	915023	25500	50-007-010
JOHN DEERE	230LC		SEALED	1.493	8.366	7.48	B3635	A3541	915042	25500	50-007-010
JOHN DEERE	230LC		SEALED	1.496	8.583	7.48	B3635	A3541	915023	25500	50-007-010
JOHN DEERE	240D		SEALED	1.496	8.583	7.48	B3635	A3541	915023	25500	50-007-010
JOHN DEERE	270CLC		SEALED	1.76	9.52	8.50	B3635	A3541	915162	25548	50-007-002
JOHN DEERE	270LC		SEALED	1.75	9.646	8.00	B3635	A3541	915121	25548	50-007-002
JOHN DEERE	290D		SEALED	1.181	6.456	6.13	A3536	A3539	915136	25498	50-007-006
JOHN DEERE	291		SEALED	1.181	6.456	6.13	A3536	A3539	915136	25498	50-007-006
JOHN DEERE	330CLC		SEALED	1.76	9.52	8.50	B3635	A3541	915162	25548	50-007-002
JOHN DEERE	330LC	EXC	SEALED	1.76	9.52	8.50	B3635	A3541	915162	25548	50-007-002
JOHN DEERE	350B		FLUSH	1.192	5.47	5.75	A3536	A3539	915065	25498	50-007-006
JOHN DEERE	350C		FLUSH	1.192	5.47	5.75	A3536	A3539	915065	25498	50-007-006
JOHN DEERE	350D		SEALED	1.192	5.38	5.75	A3536	A3539	915027	25498	50-007-006
JOHN DEERE	400G		SEALED	1.192	5.38	5.75	A3536	A3539	915027	25498	50-007-006
JOHN DEERE	420C		FLUSH	1.004	5.46875	5.75	A3536	A3539	915064	200281	50-007-007
JOHN DEERE	450B		RECESSED	1.376	6.08	6.29	B3635	A3541	915056	25499	50-007-004
JOHN DEERE	450C	S/N 216337 & DN	RECESSED	1.376	6.08	6.29	B3635	A3541	915056	25499	50-007-004
JOHN DEERE	450C		SALT	1.256	6.378	6.29	A3537	A3540	915014	25498	50-007-005
JOHN DEERE	450C	S/N 216338 & UP	SEALED	1.376	6.2	6.29	B3635	A3541	915074	25499	50-007-004
JOHN DEERE	450CLC		SEALED	1.873	10	8.50	B3815	A3541	915087	25551	50-007-002
JOHN DEERE	450D		SALT	1.256	6.378	6.29	A3537	A3540	915014	25498	50-007-005
JOHN DEERE	450D		SEALED	1.259	6.358	6.29	A3537	A3540	915046	25498	50-007-005
JOHN DEERE	450E		SEALED	1.259	6.358	6.29	A3537	A3540	915046	25498	50-007-005
JOHN DEERE	450G		SALT	1.256	6.378	6.29	A3537	A3540	915014	25498	50-007-005
JOHN DEERE	450G		SEALED	1.259	6.358	6.29	A3537	A3540	915046	25498	50-007-005
JOHN DEERE	450H		SALT	1.256	6.378	6.29	A3537	A3540	915014	25498	50-007-005
JOHN DEERE	450H		SEALED	1.259	6.358	6.29	A3537	A3540	915046	25498	50-007-005
JOHN DEERE	450J		SALT	1.256	6.378	6.29	A3537	A3540	915014	25498	50-007-005
JOHN DEERE	450J		SEALED	1.259	6.358	6.29	A3537	A3540	915046	25498	50-007-005
JOHN DEERE	450LC		SEALED	1.873	10	8.50	B3815	A3541	915087	25551	50-007-002
JOHN DEERE	455D		SEALED	1.259	6.358	6.29	A3537	A3540	915046	25498	50-007-005
JOHN DEERE	455G		SALT	1.256	6.378	6.29	A3537	A3540	915014	25498	50-007-005



WTC Machinery FP250 Tooling Chart

6/9/2022

Make	Model	Comments	Type	Pin Dimensions			Disassembly Tools		Assembly Tools		
				Dia	Length	Pitch	Pin Tool	Back. Bush.	PAT (2)	Forcing Pin	Bushing
JOHN DEERE	455G		SEALED	1.259	6.358	6.29	A3537	A3540	915046	25498	50-007-005
JOHN DEERE	490D		SEALED	1.319	7.008	6.75	A3537	A3540	915002	25499	50-007-005
JOHN DEERE	490E		SEALED	1.33	6.7	6.73	A3537	A3540	915166	25499	50-007-005
JOHN DEERE	550A		SALT	1.256	6.378	6.29	A3537	A3540	915014	25498	50-007-005
JOHN DEERE	550A		SEALED	1.259	6.358	6.29	A3537	A3540	915046	25498	50-007-005
JOHN DEERE	550B		SALT	1.256	6.378	6.29	A3537	A3540	915014	25498	50-007-005
JOHN DEERE	550B		SEALED	1.259	6.358	6.29	A3537	A3540	915046	25498	50-007-005
JOHN DEERE	550G		SALT	1.256	6.378	6.29	A3537	A3540	915014	25498	50-007-005
JOHN DEERE	550G		SEALED	1.259	6.358	6.29	A3537	A3540	915046	25498	50-007-005
JOHN DEERE	550H		SALT	1.256	6.378	6.29	A3537	A3540	915014	25498	50-007-005
JOHN DEERE	550H		SEALED	1.259	6.358	6.29	A3537	A3540	915046	25498	50-007-005
JOHN DEERE	550J		SALT	1.256	6.378	6.29	A3537	A3540	915014	25498	50-007-005
JOHN DEERE	555G		SALT	1.31	7.24	6.73	A3537	A3540	915089	25499	50-007-005
JOHN DEERE	555G		SEALED	1.318	7.224	6.29	A3537	A3540	915089	25499	50-007-005
JOHN DEERE	590D	S/N 1787 & UP	SEALED	1.366	7.598	6.75	A3537	A3540	915142	25499	50-007-004
JOHN DEERE	590D		SEALED	1.378	7.598	6.75	B3635	A3541	915002	25499	50-007-004
JOHN DEERE	650G		SALT	1.31	7.24	6.73	A3537	A3540	915089	25499	50-007-005
JOHN DEERE	650G		SEALED	1.318	7.224	6.29	A3537	A3540	915089	25499	50-007-005
JOHN DEERE	650H		SALT	1.31	7.24	6.73	A3537	A3540	915089	25499	50-007-005
JOHN DEERE	650H		SEALED	1.318	7.224	6.29	A3537	A3540	915089	25499	50-007-005
JOHN DEERE	650J		SALT	1.31	7.24	6.73	A3537	A3540	915089	25499	50-007-005
JOHN DEERE	650J		SEALED	1.318	7.224	6.29	A3537	A3540	915089	25499	50-007-005
JOHN DEERE	655B		SALT	1.44	8.11	6.99	B3635	A3541	915042	25500	50-007-004
JOHN DEERE	690A		RECESSED	1.32	6.97	6.75	A3537	A3540	915074	25499	50-007-005
JOHN DEERE	690B		RECESSED	1.32	6.97	6.75	A3537	A3540	915074	25499	50-007-005
JOHN DEERE	690C		RECESSED	1.32	6.97	6.75	A3537	A3540	915074	25499	50-007-005
JOHN DEERE	690D		RECESSED	1.32	6.97	6.75	A3537	A3540	915074	25499	50-007-005
JOHN DEERE	690E		SEALED	1.437	8.15	7.48	B3635	A3541	915079	25500	50-007-004
JOHN DEERE	690ELC		SEALED	1.437	8.15	7.48	B3635	A3541	915079	25500	50-007-004
JOHN DEERE	693B		RECESSED	1.32	6.97	6.75	A3537	A3540	915074	25499	50-007-005
JOHN DEERE	693D		SEALED	1.44	8.11	6.91	B3635	A3541	915042	25500	50-007-004
JOHN DEERE	700J		SALT	1.44	8.11	6.99	B3635	A3541	915042	25500	50-007-004
JOHN DEERE	70D		SEALED	1.19	6.102	6.06	A3536	A3539	915025	25498	50-007-006
JOHN DEERE	750B		SALT	1.44	8.11	6.99	B3635	A3541	915042	25500	50-007-004
JOHN DEERE	750B		SEALED	1.44	8.11	6.91	B3635	A3541	915042	25500	50-007-004
JOHN DEERE	750C		SALT	1.437	8.125	7.48	B3635	A3541	915052	25500	50-007-004
JOHN DEERE	750J		SALT	1.496	9.39	7.48	B3635	A3541	915080	25500-001	50-007-010
JOHN DEERE	755A		SEALED	1.753	9.13	7.98	B3635	A3541	915099	25548	50-007-002
JOHN DEERE	755B		SEALED	1.44	8.11	6.91	B3635	A3541	915042	25500	50-007-004
JOHN DEERE	755C		SALT	1.753	9.06	7.98	B3635	A3541	915106	25548	50-007-002
JOHN DEERE	755C		SEALED	1.75	9.06	8.00	B3635	A3541	915013	25548	50-007-002
JOHN DEERE	790D		SEALED	1.496	8.583	7.48	B3635	A3541	915023	25500	50-007-010
JOHN DEERE	790E		SEALED	1.493	8.366	7.48	B3635	A3541	915042	25500	50-007-010
JOHN DEERE	790ELC		SEALED	1.493	8.366	7.48	B3635	A3541	915042	25500	50-007-010
JOHN DEERE	792D		SEALED	1.75	9.646	8.00	B3635	A3541	915121	25548	50-007-002
JOHN DEERE	80C		SEALED	0.95	5.157	6.06	A3536	A3539	915074	200281	50-007-007
JOHN DEERE	850B		SALT	1.753	9.06	7.98	B3635	A3541	915106	25548	50-007-002
JOHN DEERE	850B		SEALED	1.753	9.13	7.98	B3635	A3541	915099	25548	50-007-002
JOHN DEERE	850C		SALT	1.753	9.06	7.98	B3635	A3541	915106	25548	50-007-002
JOHN DEERE	850C		SEALED	1.75	9.06	8.00	B3635	A3541	915013	25548	50-007-002
JOHN DEERE	850J		SALT	1.75	10.315	8.00	B3635	A3541	915175	25548	50-007-002
JOHN DEERE	890A		SEALED	1.878	9.902	8.50	B3815	A3541	915083	25551	50-007-002
JOHN DEERE	892D		SEALED	1.75	9.646	8.00	B3635	A3541	915121	25548	50-007-002
JOHN DEERE	892E		SEALED	1.75	9.646	8.00	B3635	A3541	915121	25548	50-007-002
JOHN DEERE	950J		SALT	1.87	10.86	8.50	B3815	A3541	915189	25551	50-007-002
JOHN DEERE	992D		SEALED	1.873	10	8.50	B3815	A3541	915087	25551	50-007-002
JOHN DEERE	992E		SEALED	1.873	10	8.50	B3815	A3541	915087	25551	50-007-002
JOHN DEERE	EX120		SEALED	1.319	7.008	6.75	A3537	A3540	915002	25499	50-007-005
JOHN DEERE	EX120-2		SEALED	1.33	6.7	6.73	A3537	A3540	915166	25499	50-007-005
JOHN DEERE	EX150		SEALED	1.378	7.598	6.75	B3635	A3541	915002	25499	50-007-004
JOHN DEERE	JD700		SEALED	1.44	8.11	6.91	B3635	A3541	915042	25500	50-007-004
JOHN DEERE	JD700HLGP		SALT	1.44	8.11	6.99	B3635	A3541	915042	25500	50-007-004
JOHN DEERE	JD700HLGP		SEALED	1.44	8.11	6.91	B3635	A3541	915042	25500	50-007-004
KOBELCO	K909A		UNSEALED	1.496	8.58	7.48	B3635	A3541	915023	25500	50-007-010
KOMATSU	D455A-1	S/N 1090-1333	SALT	2.76	14.37	12.50	B3605/6	A6212	915090	25553L	50-021-4
KOMATSU	EX1800	133 mm	SALT	2.76	13.78	12.51	B3605/6	A6212	915107	25553L	50-021-4
KOMATSU	D120-15		SEALED	1.988	11.3	9.00	B3815	A3541	915055	25501	50-007-001
KOMATSU	D120-18		SEALED	1.988	11.3	9.00	B3815	A3541	915055	25501	50-007-001
KOMATSU	D120-8		SEALED	1.988	11.3	9.00	B3815	A3541	915055	25501	50-007-001



WTC Machinery FP250 Tooling Chart

6/9/2022

Make	Model	Comments	Type	Pin Dimensions			Disassembly Tools		Assembly Tools		
				Dia	Length	Pitch	Pin Tool	Back. Bush.	PAT (2)	Forcing Pin	Bushing
KOMATSU	D125-18		RECESSED	1.988	11.3	9.00	B3815	A3541	915206	25501	50-007-001
KOMATSU	D135A-1			1.909	11.575	9.00	B3815	A3541	915087	25551	50-007-002
KOMATSU	D150-1		SALT	1.909	11.57	9.00	B3815	A3541	915055	25551	50-007-002
KOMATSU	D150-1	S/N 6843 & UP	SEALED	1.929	11.54	9.00	B3815	A3541	915086	25551	50-007-002
KOMATSU	D150-1	S/N 6842 & DN	SEALED	1.988	11.3	9.00	B3815	A3541	915055	25501	50-007-001
KOMATSU	D150-1	S/N 6843 & UP	UNSEALED	1.929	11.535	9.00	B3815	A3541	915086	25551	50-007-002
KOMATSU	D150-1	S/N 6842 & DN	UNSEALED	1.988	11.299	9.00	B3815	A3541	915055	25501	50-007-001
KOMATSU	D155		SALT	1.909	11.57	9.00	B3815	A3541	915055	25551	50-007-002
KOMATSU	D155		SEALED	1.988	11.3	9.00	B3815	A3541	915055	25501	50-007-001
KOMATSU	D155-1		SALT	1.909	11.57	9.00	B3815	A3541	915055	25551	50-007-002
KOMATSU	D155-1	S/N 6843 & UP	SEALED	1.929	11.54	9.00	B3815	A3541	915086	25551	50-007-002
KOMATSU	D155-1	S/N 6842 & DN	SEALED	1.988	11.3	9.00	B3815	A3541	915055	25501	50-007-001
KOMATSU	D155-1	S/N 6843 & UP	UNSEALED	1.929	11.535	9.00	B3815	A3541	915086	25551	50-007-002
KOMATSU	D155-1	S/N 19065 & UP	SALT	1.9094	11.574	9.00	B3815	A3541	915087	25551	50-007-002
KOMATSU	D155-1	S/N 10263-19064	SEALED	1.9069	11.5747	9.00	B3815	A3541	915087	25551	50-007-002
KOMATSU	D155-1	S/N 6842 & DN	UNSEALED	1.988	11.299	9.00	B3815	A3541	915055	25501	50-007-001
KOMATSU	D155A		SALT	1.909	11.57	9.00	B3815	A3541	915055	25551	50-007-002
KOMATSU	D155A-1	S/N 2540-10262	SEALED	1.909	11.3	9.00	B3815	A3541	915055	25551	50-007-002
KOMATSU	D155A-2		SALT	1.9094	11.574	9.00	B3815	A3541	915087	25551	50-007-002
KOMATSU	D155A-2		SEALED	1.909	11.48	9.00	B3815	A3541	915087	25551	50-007-002
KOMATSU	D155A-5		SEALED	1.909	11.48	9.00	B3815	A3541	915167	25551	50-007-002
KOMATSU	D155AX-3		SEALED	1.909	11.48	9.00	B3815	A3541	915167	25551	50-007-002
KOMATSU	D155AX-5		SEALED	1.909	11.48	9.00	B3815	A3541	915167	25551	50-007-002
KOMATSU	D20		SALT	0.945	5.55	5.31	A3536	A3539	915123	200281	50-007-007
KOMATSU	D20		SEALED	0.945	5.63	5.31	A3536	A3539	915124	200281	50-007-007
KOMATSU	D21		SALT	0.945	5.55	5.31	A3536	A3539	915123	200281	50-007-007
KOMATSU	D21		SEALED	0.945	5.63	5.31	A3536	A3539	915124	200281	50-007-007
KOMATSU	D250		RECESSED	2.165	12.323	10.25	B3607/8	A3541	915054	25501	50-007-001
KOMATSU	D275A-2		SALT	2.24	12.61	10.25	B3607/8	A3541	915063	25501L	50-021-1
KOMATSU	D275AX	Dual Bushing	SALT	2.07	11.43	10.25	B3815	A3541	915093	25501	50-007-001
KOMATSU	D275AX-5	SALT	SALT	2.24	11.36	10.25	B3607/8	A3541	915063	25501	50-021-1
KOMATSU	D30-15		SEALED	1.102	6.594	6.06	A3536	A3539	915057	200281	50-007-006
KOMATSU	D30A		SEALED	1.102	6.594	6.06	A3536	A3539	915057	200281	50-007-006
KOMATSU	D30S-1		SEALED	1.094	6.59	6.06	A3536	A3539	915058	200281	50-007-006
KOMATSU	D30S-15	S/N 5016 & UP	SEALED	1.102	6.594	6.06	A3536	A3539	915057	200281	50-007-006
KOMATSU	D31		UNSEALED	1.18	6.69	6.06	A3536	A3539	915069	25498	50-007-006
KOMATSU	D31-15		SEALED	1.102	6.594	6.06	A3536	A3539	915057	200281	50-007-006
KOMATSU	D31-16		SALT	1.102	6.6929	6.06	A3536	A3539	915058	200281	50-007-006
KOMATSU	D31-16		SEALED	1.102	6.693	6.06	A3536	A3539	915058	200281	50-007-006
KOMATSU	D31E		SALT	1.102	6.6929	6.06	A3536	A3539	915058	200281	50-007-006
KOMATSU	D31E-12		SEALED	1.102	6.594	6.06	A3536	A3539	915057	200281	50-007-006
KOMATSU	D31P		SALT	1.102	6.6929	6.06	A3536	A3539	915058	200281	50-007-006
KOMATSU	D31P		UNSEALED	1.18	6.69	6.06	A3536	A3539	915069	25498	50-007-006
KOMATSU	D31P-20		SALT	1.102	6.6929	6.06	A3536	A3539	915058	200281	50-007-006
KOMATSU	D31PL		SALT	1.102	6.6929	6.06	A3536	A3539	915058	200281	50-007-006
KOMATSU	D31PLL	S/N 29001 & UP	SALT	1.102	6.6929	6.06	A3536	A3539	915058	200281	50-007-006
KOMATSU	D31PX		SALT	1.102	6.6929	6.06	A3536	A3539	915058	200281	50-007-006
KOMATSU	D31S		SALT	1.102	6.6929	6.06	A3536	A3539	915058	200281	50-007-006
KOMATSU	D355		FLUSH	2.244	12.579	10.25	B3607/8	A3541	915053	25501L	50-021-1
KOMATSU	D355		SALT	2.185	12.736	10.25	B3607/8	A3541	915091	25501L	50-007-001
KOMATSU	D355A-1	S/N 1010-1631	SEALED	2.244	12.578	10.25	B3607/8	A3541	915088	25501L	50-021-1
KOMATSU	D355A-3	S/N 4234 & UP	SALT	2.185	12.736	10.25	B3607/8	A3541	915091	25501L	50-007-001
KOMATSU	D355A-3	S/N 1632-4233	SEALED	2.185	12.736	10.25	B3607/8	A3541	915091	25501L	50-007-001
KOMATSU	D37		SALT	1.102	6.6929	6.06	A3536	A3539	915058	200281	50-007-006
KOMATSU	D375		SALT	2.24	12.61	10.25	B3607/8	A3541	915063	25501L	50-021-1
KOMATSU	D375A-1		SALT	2.24	12.61	10.25	B3607/8	A3541	915063	25501L	50-021-1
KOMATSU	D375A-2		SALT	2.36	12.77	11.04	B3607/8	A3541	915131	25553L	50-021-2
KOMATSU	D375A-3		SALT	2.36	12.77	11.04	B3607/8	A3541	915131	25553L	50-021-2
KOMATSU	D375A-5		SALT	2.362	12.77	11.04	B3607/8	A3541	915165	25553L	50-021-2
KOMATSU	D37P		SALT	1.102	6.6929	6.06	A3536	A3539	915058	200281	50-007-006
KOMATSU	D39E		SALT	1.307	7.244	6.75	A3537	A3540	915052	25499	50-007-005
KOMATSU	D39EX		SALT	1.307	7.244	6.75	A3537	A3540	915052	25499	50-007-005
KOMATSU	D39P		SALT	1.307	7.244	6.75	A3537	A3540	915052	25499	50-007-005
KOMATSU	D39PX		SALT	1.307	7.244	6.75	A3537	A3540	915052	25499	50-007-005
KOMATSU	D40		RECESSED	1.488	8.5826	6.89	B3635	A3541	915059	25500	50-007-010
KOMATSU	D40		SALT	1.377	7.13	6.89	B3635	A3541	915060	25499	50-007-004
KOMATSU	D40		SEALED	1.382	7.17	6.89	B3635	A3541	915060	25499	50-007-004
KOMATSU	D40P-1	BERCO	SEALED	1.496	8.661	6.91	B3635	A3541	915059	25500	50-007-010
KOMATSU	D41	NEW	SALT	1.382	7.17	6.89	B3635	A3541	915122	25499	50-007-004



WTC Machinery FP250 Tooling Chart

6/9/2022

Make	Model	Comments	Type	Pin Dimensions			Disassembly Tools		Assembly Tools		
				Dia	Length	Pitch	Pin Tool	Back. Bush.	PAT (2)	Forcing Pin	Bushing
KOMATSU	D41		SEALED	1.382	7.17	6.89	B3635	A3541	915060	25499	50-007-004
KOMATSU	D41		UNSEALED	1.499	8.66	6.89	B3635	A3541	915122	25500	50-007-010
KOMATSU	D41-6		SALT	1.307	7.244	6.75	A3537	A3540	915052	25499	50-007-005
KOMATSU	D41A	BERCO	SEALED	1.496	8.661	6.91	B3635	A3541	915059	25500	50-007-010
KOMATSU	D41E	S/N 50201 & UP	SEALED	1.307	7.224	6.75	A3537	A3540	915067	25499	50-007-005
KOMATSU	D41E		SALT	1.307	7.244	6.75	A3537	A3540	915052	25499	50-007-005
KOMATSU	D41P		SALT	1.307	7.244	6.75	A3537	A3540	915052	25499	50-007-005
KOMATSU	D41P	BERCO	SEALED	1.496	8.661	6.91	B3635	A3541	915059	25500	50-007-010
KOMATSU	D41P-6	S/N 50201 & UP	SALT	1.307	7.224	6.75	A3537	A3540	915067	25499	50-007-005
KOMATSU	D41PX-12		SALT	1.432	7.845	6.88	B3635	A3541	915163	25500	50-007-004
KOMATSU	D41Q-3	BERCO	SEALED	1.496	8.661	6.91	B3635	A3541	915059	25500	50-007-010
KOMATSU	D41S	BERCO	SEALED	1.496	8.661	6.91	B3635	A3541	915059	25500	50-007-010
KOMATSU	D45		RECESSED	1.488	8.5826	6.89	B3635	A3541	915059	25500	50-007-010
KOMATSU	D455		SALT	2.76	14.37	12.50	B3605/6	A6212	915090	25553L	50-021-4
KOMATSU	D455A-1	S/N 1334 & UP	SALT	2.7559	14.37	12.50	B3605/6	A6212	915090	25553L	50-021-4
KOMATSU	D455A-1	S/N 1004-1089	SALT	2.76	14.37	12.50	B3605/6	A6212	915090	25553L	50-021-4
KOMATSU	D45A		SEALED	1.382	7.17	6.89	B3635	A3541	915059	25499	50-007-004
KOMATSU	D45A	S/N 12178+ BRCO	SEALED	1.496	8.661	6.91	B3635	A3541	915059	25500	50-007-010
KOMATSU	D45B	S/N 12178+ BRCO	SEALED	1.496	8.661	6.91	B3635	A3541	915059	25500	50-007-010
KOMATSU	D45P-1	S/N 1501 & UP	SEALED	1.382	7.17	6.89	B3635	A3541	915059	25499	50-007-004
KOMATSU	D475A-1		SALT	2.76	14.4	12.51	B3605/6	A6212	915107	25553L	50-021-4
KOMATSU	D475A-2		SALT	2.76	14.4	12.51	B3605/6	A6212	915107	25553L	50-021-4
KOMATSU	D475A-3		SALT	2.76	13.78	12.51	B3605/6	A6212	915239	25553L	50-021-4
KOMATSU	D475A-5		SALT	2.76	13.78	12.51	B3605/6	A6212	915238	25553L	50-021-4
KOMATSU	D50		RECESSED	1.488	8.5826	6.89	B3635	A3541	915059	25500	50-007-010
KOMATSU	D50		SALT	1.377	7.13	6.89	B3635	A3541	915060	25499	50-007-004
KOMATSU	D50		SEALED	1.382	7.17	6.89	B3635	A3541	915060	25499	50-007-004
KOMATSU	D50-11		RECESSED	1.488	8.5826	6.89	B3635	A3541	915059	25500	50-007-010
KOMATSU	D50-15		RECESSED	1.488	8.5826	6.89	B3635	A3541	915059	25500	50-007-010
KOMATSU	D50-15		SEALED	1.382	7.17	6.89	B3635	A3541	915059	25499	50-007-004
KOMATSU	D50A	BERCO	SEALED	1.496	8.661	6.91	B3635	A3541	915059	25500	50-007-010
KOMATSU	D50B	S/N 10901+ BRCO	SEALED	1.496	8.661	6.91	B3635	A3541	915059	25500	50-007-010
KOMATSU	D50P	S/N 10901+ BRCO	SEALED	1.496	8.661	6.91	B3635	A3541	915059	25500	50-007-010
KOMATSU	D50S	S/N 10901+ BRCO	SEALED	1.496	8.661	6.91	B3635	A3541	915059	25500	50-007-010
KOMATSU	D50S-11		RECESSED	1.488	8.5826	6.89	B3635	A3541	915059	25500	50-007-010
KOMATSU	D53	NEW	SALT	1.382	7.17	6.89	B3635	A3541	915122	25499	50-007-004
KOMATSU	D53		UNSEALED	1.499	8.66	6.89	B3635	A3541	915122	25500	50-007-010
KOMATSU	D53		SALT	1.377	7.13	6.89	B3635	A3541	915060	25499	50-007-004
KOMATSU	D53-15		SEALED	1.382	7.17	6.89	B3635	A3541	915059	25499	50-007-004
KOMATSU	D53-16		SEALED	1.382	7.17	6.89	B3635	A3541	915060	25499	50-007-004
KOMATSU	D53A	BERCO	SEALED	1.496	8.661	6.91	B3635	A3541	915059	25500	50-007-010
KOMATSU	D53A-15	S/N 60001 & UP	SEALED	1.382	7.17	6.89	B3635	A3541	915059	25499	50-007-004
KOMATSU	D55		SEALED	1.496	8.661	7.48	B3635	A3541	915060	25500	50-007-010
KOMATSU	D55-S		RECESSED	1.488	8.583	7.48	B3635	A3541	915056	25500	50-007-010
KOMATSU	D57-1		SEALED	1.496	8.661	7.48	B3635	A3541	915060	25500	50-007-010
KOMATSU	D575-1		DRY	1.5	8.66	7.48	B3635	A3541	915233	25500	50-007-010
KOMATSU	D575A-2		SALT	2.913	17.32	12.51	B3605/6	A6212		25553L	50-021-4
KOMATSU	D575A-3		SALT	2.913	17.32	12.51	B3605/6	A6212		25553L	50-021-4
KOMATSU	D57S-1		SEALED	1.496	8.661	7.48	B3635	A3541	915060	25500	50-007-010
KOMATSU	D58		SALT	1.377	7.13	6.89	B3635	A3541	915060	25499	50-007-004
KOMATSU	D58		SEALED	1.382	7.17	6.89	B3635	A3541	915060	25499	50-007-004
KOMATSU	D58E	BERCO	SEALED	1.496	8.661	6.91	B3635	A3541	915059	25500	50-007-010
KOMATSU	D58P-1	BERCO	SEALED	1.496	8.661	6.91	B3635	A3541	915059	25500	50-007-010
KOMATSU	D6	S/N 50001-50200	SALT	1.307	7.244	6.75	A3537	A3540	915052	25499	50-007-005
KOMATSU	D60		SALT	1.75	9.433	8.00	B3635	A3541	915084	25548	50-007-002
KOMATSU	D60		SEALED	1.76	9.433	8.00	B3635	A3541	915084	25548	50-007-002
KOMATSU	D60-6		SEALED	1.752	9.26	8.00	B3635	A3541	915062	25548	50-007-002
KOMATSU	D60A	BERCO NON-OEM	SEALED	1.756	9.449	7.98	B3635	A3541	915116	25548	50-007-002
KOMATSU	D60-A		RECESSED	1.488	8.583	7.48	B3635	A3541	915056	25500	50-007-010
KOMATSU	D61		SALT	1.496	8.897	7.48	B3635	A3541	915060	25500	50-007-010
KOMATSU	D61E		SALT	1.496	8.897	7.48	B3635	A3541	915060	25500	50-007-010
KOMATSU	D61EX		SALT	1.496	8.897	7.48	B3635	A3541	915060	25500	50-007-010
KOMATSU	D61P		SALT	1.496	8.897	7.48	B3635	A3541	915060	25500	50-007-010
KOMATSU	D61PX		SALT	1.496	8.897	7.48	B3635	A3541	915060	25500	50-007-010
KOMATSU	D61PX-12		SALT	1.496	8.897	7.48	B3635	A3541	915060	25500	50-007-010
KOMATSU	D63E		SALT	1.377	7.13	6.89	B3635	A3541	915060	25499	50-007-004
KOMATSU	D63E		SEALED	1.382	7.17	6.89	B3635	A3541	915060	25499	50-007-004
KOMATSU	D65		SALT	1.75	9.433	8.00	B3635	A3541	915084	25548	50-007-002
KOMATSU	D65		SEALED	1.76	9.433	8.00	B3635	A3541	915084	25548	50-007-002



WTC Machinery FP250 Tooling Chart

6/9/2022

Make	Model	Comments	Type	Pin Dimensions			Disassembly Tools		Assembly Tools		
				Dia	Length	Pitch	Pin Tool	Back. Bush.	PAT (2)	Forcing Pin	Bushing
KOMATSU	D65-6	S/N 34001 & UP	SALT	1.7559	9.5275	8.00	B3635	A3541	915097	25548	50-007-002
KOMATSU	D65A	BERCO NON-OEM	SEALED	1.756	9.449	7.98	B3635	A3541	915116	25548	50-007-002
KOMATSU	D65A		SEALED	1.76	9.433	8.00	B3635	A3541	915084	25548	50-007-002
KOMATSU	D65E		SEALED	1.76	9.433	8.00	B3635	A3541	915084	25548	50-007-002
KOMATSU	D65EX-12		SALT	1.75	9.433	8.00	B3635	A3541	915084	25548	50-007-002
KOMATSU	D65EX-15		SALT	1.75	9.433	8.00	B3635	A3541	915084	25548	50-007-002
KOMATSU	D65P-6	S/N 20006 & UP	SEALED	1.76	9.433	8.00	B3635	A3541	915084	25548	50-007-002
KOMATSU	D65PX		SALT	1.75	9.433	8.00	B3635	A3541	915084	25548	50-007-002
KOMATSU	D65PX-12		SALT	1.75	9.433	8.00	B3635	A3541	915084	25548	50-007-002
KOMATSU	D65PX-15		SALT	1.75	9.433	8.00	B3635	A3541	915084	25548	50-007-002
KOMATSU	D66		SALT	1.7559	9.5275	8.00	B3635	A3541	915097	25548	50-007-002
KOMATSU	D66		SEALED	1.76	9.433	8.00	B3635	A3541	915084	25548	50-007-002
KOMATSU	D68		SALT	1.7559	9.5275	8.00	B3635	A3541	915097	25548	50-007-002
KOMATSU	D68		SEALED	1.76	9.433	8.00	B3635	A3541	915084	25548	50-007-002
KOMATSU	D75		SALT	1.8503	10	8.50	B3635	A3541	915096	25551	50-007-002
KOMATSU	D75		SEALED	1.8425	10	8.50	B3635	A3541	915096	25551	50-007-002
KOMATSU	D75-S		SEALED	1.85	9.842	8.50	B3635	A3541	915015	25551	50-007-002
KOMATSU	D80		SALT	1.8503	10	8.50	B3635	A3541	915096	25551	50-007-002
KOMATSU	D80		SEALED	1.8425	10	8.50	B3635	A3541	915096	25551	50-007-002
KOMATSU	D80-7		SEALED	1.752	9.842	8.00	B3635	A3541	915013	25548	50-007-002
KOMATSU	D80-8		SEALED	1.752	9.842	8.00	B3635	A3541	915013	25548	50-007-002
KOMATSU	D85		SALT	1.8503	10	8.50	B3635	A3541	915096	25551	50-007-002
KOMATSU	D85		SEALED	1.771	9.842	8.50	B3635	A3541	915085	25548	50-007-002
KOMATSU	D85-18	S/N 26514 & UP	SALT	1.8503	10	8.50	B3635	A3541	915096	25551	50-007-002
KOMATSU	D85-18	S/N 26513 & DN	SEALED	1.85	10	8.50	B3635	A3541	915232	25551	50-007-002
KOMATSU	D85A		SEALED	1.771	9.842	8.50	B3635	A3541	915085	25548	50-007-002
KOMATSU	D85A		SEALED	1.8425	10	8.50	B3635	A3541	915096	25551	50-007-002
KOMATSU	D85A-12		SEALED	1.85	9.842	8.50	B3635	A3541	915015	25551	50-007-002
KOMATSU	D85E		SEALED	1.8425	10	8.50	B3635	A3541	915096	25551	50-007-002
KOMATSU	D85E-12	S/N 10001 & UP	SEALED	1.771	9.842	8.50	B3635	A3541	915085	25548	50-007-002
KOMATSU	D85E-12		SEALED	1.771	9.842	8.50	B3635	A3541	915085	25548	50-007-002
KOMATSU	D85EX-15		SALT	1.8503	10	8.50	B3635	A3541	915096	25551	50-007-002
KOMATSU	D85P-18		SEALED	1.8425	10	8.50	B3635	A3541	915096	25551	50-007-002
KOMATSU	D85PX		SALT	1.8503	10	8.50	B3635	A3541	915096	25551	50-007-002
KOMATSU	D85PX-15		SALT	1.8503	10	8.50	B3635	A3541	915096	25551	50-007-002
KOMATSU	D95		SALT	1.8503	10	8.50	B3635	A3541	915096	25551	50-007-002
KOMATSU	D95		SEALED	1.8425	10	8.50	B3635	A3541	915096	25551	50-007-002
KOMATSU	D95-S		SEALED	1.772	10	8.50	B3635	A3541	915232	25548	50-007-002
KOMATSU	PC100	PITCH ALSO 6.89	SEALED	1.181	6.811	6.06	A3536	A3539	915126	25498	50-007-006
KOMATSU	PC100		SEALED	1.18	6.81	6.89	A3536	A3539	915161	25498	50-007-006
KOMATSU	PC100		UNSEALED	1.18	6.69	6.06	A3536	A3539	915069	25498	50-007-006
KOMATSU	PC1000		SEALED	2.244	12.614	10.25	B3607/8	A3541	915063	25501L	50-021-1
KOMATSU	PC1000-1		SALT	2.24	12.61	10.25	B3607/8	A3541	915063	25501L	50-021-1
KOMATSU	PC1000SE-1		SALT	2.24	12.61	10.25	B3607/8	A3541	915063	25501L	50-021-1
KOMATSU	PC100-1		SEALED	1.181	6.535	6.06	A3536	A3539	915110	25498	50-007-006
KOMATSU	PC100-2		SEALED	1.181	6.535	6.06	A3536	A3539	915110	25498	50-007-006
KOMATSU	PC100-3		SEALED	1.181	6.535	6.06	A3536	A3539	915110	25498	50-007-006
KOMATSU	PC100-6		SEALED	1.18	6.81	6.89	A3536	A3539	915161	25498	50-007-006
KOMATSU	PC100L-6		SEALED	1.49	8.66	7.49	B3635	A3541	915060	25500	50-007-010
KOMATSU	PC1100-6		DRY	2.36	12.77	11.03	B3607/8	A3541	915131	25553L	50-021-2
KOMATSU	PC1100LC-6		DRY	2.36	12.77	11.03	B3607/8	A3541	915131	25553L	50-021-2
KOMATSU	PC1100SP-6		DRY	2.36	12.77	11.03	B3607/8	A3541	915131	25553L	50-021-2
KOMATSU	PC120		SEALED	1.18	6.81	6.89	A3536	A3539	915161	25498	50-007-006
KOMATSU	PC120	PITCH ALSO 6.89	SEALED	1.181	6.811	6.06	A3536	A3539	915126	25498	50-007-006
KOMATSU	PC120-1		SEALED	1.181	6.535	6.06	A3536	A3539	915110	25498	50-007-006
KOMATSU	PC120-2		SEALED	1.181	6.535	6.06	A3536	A3539	915110	25498	50-007-006
KOMATSU	PC120-3		SEALED	1.181	6.535	6.06	A3536	A3539	915110	25498	50-007-006
KOMATSU	PC120-6			1.181	6.811	6.89	A3536	A3539	915126	25498	50-007-006
KOMATSU	PC120-6			1.181	6.811	6.90	A3536	A3539	915231	25498	50-007-006
KOMATSU	PC120LC-6		SEALED	1.18	6.81	6.89	A3536	A3539	915161	25498	50-007-006
KOMATSU	PC1250		DRY	2.36	12.77	11.03	B3607/8	A3541	915131	25553L	50-021-2
KOMATSU	PC1250-7		DRY	2.36	12.77	11.03	B3607/8	A3541	915131	25553L	50-021-2
KOMATSU	PC1250LC-7		DRY	2.36	12.77	11.03	B3607/8	A3541	915131	25553L	50-021-2
KOMATSU	PC1250SP-7		DRY	2.36	12.77	11.03	B3607/8	A3541	915131	25553L	50-021-2
KOMATSU	PC130-6		SEALED	1.18	6.81	6.89	A3536	A3539	915161	25498	50-007-006
KOMATSU	PC138		SEALED	1.18	6.81	6.89	A3536	A3539	915161	25498	50-007-006
KOMATSU	PC150		DRY	1.499	8.66	6.89	B3635	A3541	915122	25500	50-007-010
KOMATSU	PC1600		SALT	2.76	13.78	12.51	B3605/6	A6212	915107	25553L	50-021-4
KOMATSU	PC1800	133 mm	SALT	2.76	13.78	12.51	B3605/6	A6212	915107	25553L	50-021-4



WTC Machinery FP250 Tooling Chart

6/9/2022

Make	Model	Comments	Type	Pin Dimensions			Disassembly Tools		Assembly Tools		
				Dia	Length	Pitch	Pin Tool	Back. Bush.	PAT (2)	Forcing Pin	Bushing
KOMATSU	PC200		SEALED	1.496	8.661	7.48	B3635	A3541	915060	25500	50-007-010
KOMATSU	PC2000		SALT	2.76	13.78	12.51	B3605/6	A6212	915107	25553L	50-021-4
KOMATSU	PC200-6		SEALED	1.496	8.661	7.48	B3635	A3541	915060	25500	50-007-010
KOMATSU	PC200-7		SEALED	1.496	8.661	7.48	B3635	A3541	915060	25500	50-007-010
KOMATSU	PC200-8		SEALED	1.496	8.661	7.48	B3635	A3541	915060	25500	50-007-010
KOMATSU	PC220		SEALED	1.496	8.661	7.48	B3635	A3541	915060	25500	50-007-010
KOMATSU	PC240LC-6		SEALED	1.496	8.661	7.48	B3635	A3541	915060	25500	50-007-010
KOMATSU	PC250LC-6		SEALED	1.75	9.52	8.50	B3635	A3541	915159	25548	50-007-002
KOMATSU	PC270LC-6		SEALED	1.75	9.52	8.50	B3635	A3541	915159	25548	50-007-002
KOMATSU	PC270LC-7		SEALED	1.75	9.52	8.50	B3635	A3541	915159	25548	50-007-002
KOMATSU	PC300	EXC	SALT	1.75	9.53	8.00	B3635	A3541	915097	25548	50-007-002
KOMATSU	PC300	EXC	SEALED	1.76	9.53	8.00	B3635	A3541	915076	25548	50-007-002
KOMATSU	PC300HD-6		SEALED	1.85	9.92	9.00	B3635	A3541	915160	25551	50-007-002
KOMATSU	PC300LC-6		SEALED	1.75	9.52	8.50	B3635	A3541	915159	25548	50-007-002
KOMATSU	PC300LC-7		SEALED	1.75	9.52	8.50	B3635	A3541	915159	25548	50-007-002
KOMATSU	PC-400 EX		SEALED	1.85	10	8.50	B3635	A3541	915232	25551	50-007-002
KOMATSU	PC400-3		SEALED	1.8425	10	8.50	B3635	A3541	915096	25551	50-007-002
KOMATSU	PC400-5		SEALED	1.8425	10	8.50	B3635	A3541	915096	25551	50-007-002
KOMATSU	PC400-6		SEALED	1.85	10	9.00	B3635	A3541	915096	25551	50-007-002
KOMATSU	PC400-6		SEALED	1.8425	10	8.50	B3635	A3541	915096	25551	50-007-002
KOMATSU	PC400LC-7		SEALED	1.85	10	9.00	B3635	A3541	915096	25551	50-007-002
KOMATSU	PC400LCSE-7		SEALED	1.85	10	9.00	B3635	A3541	915096	25551	50-007-002
KOMATSU	PC450		SEALED	1.85	10	9.00	B3635	A3541	915096	25551	50-007-002
KOMATSU	PC60	EXC	SEALED	0.945	5.55	5.31	A3536	A3539	915123	200281	50-007-007
KOMATSU	PC600		SEALED	2.185	12.614	10.25	B3607/8	A3541	915125	25501L	50-007-001
KOMATSU	PC600	EXC	SEALED	1.85	10	8.50	B3635	A3541	915232	25551	50-007-002
KOMATSU	PC600-6			1.92	11.41	9.00	B3815	A3541	915177	25551	50-007-002
KOMATSU	PC600-7			1.92	11.41	9.00	B3815	A3541	915177	25551	50-007-002
KOMATSU	PC600LC-6			1.92	11.41	9.00	B3815	A3541	915177	25551	50-007-002
KOMATSU	PC600LC-7			1.92	11.41	9.00	B3815	A3541	915177	25551	50-007-002
KOMATSU	PC650-5		SEALED	2.185	12.614	10.25	B3607/8	A3541	915125	25501L	50-007-001
KOMATSU	PC700		SEALED	2.185	12.614	10.25	B3607/8	A3541	915125	25501L	50-007-001
KOMATSU	PC710		SEALED	2.185	12.614	10.25	B3607/8	A3541	915125	25501L	50-007-001
KOMATSU	PC750		DRY	2.2	12.61	10.25	B3607/8	A3541	915125	25501L	50-007-001
KOMATSU	PC750SE-6		SEALED	2.185	12.614	10.25	B3607/8	A3541	915125	25501L	50-007-001
KOMATSU	PC80	PITCH ALSO 6.89	SEALED	1.181	6.811	6.06	A3536	A3539	915126	25498	50-007-006
KOMATSU	PC800		SEALED	2.185	12.614	10.25	B3607/8	A3541	915125	25501L	50-007-001
KOMATSU	PC80-1		SEALED	1.181	6.535	6.06	A3536	A3539	915110	25498	50-007-006
KOMATSU	PC80-3		SEALED	1.181	6.535	6.06	A3536	A3539	915110	25498	50-007-006
KUBOTA	KH170L	EXC	UNSEALED	0.994	5.51	5.31	A3536	A3539	915040	200281	50-007-007
LIEBHERR	631	MAY WORK	SALT	1.752	9.06	7.99	B3635	A3541	915003	25548	50-007-002
LIEBHERR	PR711		SALT	1.315	7.22	6.74	A3537	A3540	915052	25499	50-007-005
LIEBHERR	PR721		SALT	1.442	8.12	6.74	B3635	A3541	915052	25500	50-007-004
LIEBHERR	PR731		SALT	1.752	9.06	7.99	B3635	A3541	915003	25548	50-007-002
LIEBHERR	R912		SEALED	1.314	7	6.74	A3537	A3540	915002	25499	50-007-005
LIEBHERR	R922		SEALED	1.314	7	6.74	A3537	A3540	915002	25499	50-007-005
LIEBHERR	R932		SEALED	1.442	8.13	6.74	B3635	A3541	915009	25500	50-007-004
LINKBELT	LS2800		SEALED	1.442	8.13	6.74	B3635	A3541	915009	25500	50-007-004
LINKBELT	LS4800		SEALED	1.878	9.88	8.50	B3815	A3541	915012	25551	50-007-002
LINKBELT	LS5400		SEALED	1.878	9.88	8.50	B3815	A3541	915012	25551	50-007-002
LINKBELT	LS5800		SEALED	1.878	9.88	8.50	B3815	A3541	915012	25551	50-007-002
LINKBELT	LS6400		SEALED	2.003	11.44	9.00	B3815	A3541	915001	25501	50-007-001
LINKBELT	LS7400		SEALED	2.003	11.44	9.00	B3815	A3541	915001	25501	50-007-001
LINKBELT	LS7800		SEALED	1.442	8.13	6.74	B3635	A3541	915009	25500	50-007-004
LINKBELT	LS9800		SEALED	1.752	9.88	7.99	B3635	A3541	915012	25548	50-007-002
MASSEY-FERG.	MF200B		SEALED	1.063	5.75	5.51	A3536	A3539	915004	200281	50-007-007
MASSEY-FERG.	MF2244		RECESSED	0.984	5.42	5.51	A3536	A3539	915057	200281	50-007-007
MASSEY-FERG.	MF300		RECESSED	1.299	6.61	6.30	A3537	A3540	915002	25498	50-007-005
MASSEY-FERG.	MF300		SEALED	1.299	6.61	6.30	A3537	A3540	915078	25498	50-007-005
MASSEY-FERG.	MF400C		SEALED	1.38	7.01	6.69	B3635	A3541	915078	25499	50-007-004
MASSEY-FERG.	MF450		RECESSED	1.299	6.61	6.30	A3537	A3540	915002	25498	50-007-005
MASSEY-FERG.	MF500		RECESSED	1.378	7.17	6.69	B3635	A3541	915080	25499	50-007-004
MASSEY-FERG.	MF500B		SEALED	1.441	8.11	6.75	B3635	A3541	915079	25500	50-007-004
MASSEY-FERG.	MF600C		SEALED	1.752	8.66	7.98	B3635	A3541	915081	25548	50-007-002
MASSEY-FERG.	MFD400C		SEALED	1.38	7.01	6.69	B3635	A3541	915078	25499	50-007-004
MASSEY-FERG.	MFD700C		SEALED	1.88	9.88	8.50	B3815	A3541	915062	25551	50-007-002
TEREX	82-20AA		RECESSED	1.75	9.19	8.00	B3635	A3541	915075	25548	50-007-002
TEREX	82-30		RECESSED	1.75	9.19	8.00	B3635	A3541	915075	25548	50-007-002
TEREX	82-30AA		RECESSED	1.75	11.52	8.00	B3635	A3541	915021	25548	50-007-002



WTC Machinery FP250 Tooling Chart

6/9/2022

Make	Model	Comments	Type	Pin Dimensions			Disassembly Tools		Assembly Tools		
				Dia	Length	Pitch	Pin Tool	Back. Bush.	PAT (2)	Forcing Pin	Bushing
TEREX	82-30B		RECESSED	2	11.52	9.00	B3815	A3541	915077	25501	50-007-001
TEREX	82-30FA		RECESSED	1.75	11.52	8.00	B3635	A3541	915021	25548	50-007-002
TEREX	82-40AA		RECESSED	1.75	11.52	8.00	B3635	A3541	915021	25548	50-007-002
TEREX	82-40CA		RECESSED	1.75	11.52	8.00	B3635	A3541	915021	25548	50-007-002
TEREX	82-40DA		RECESSED	2	11.52	9.00	B3815	A3541	915077	25501	50-007-001
TEREX	82-50		RECESSED	2.38	12.38	10.31	B3607/8	A3541	915063	25553L	50-021-2
TEREX	82-80DA		RECESSED	2	12.38	9.00	B3815	A3541	915076	25501L	50-007-001
TEREX	TC-12		RECESSED	2	12.38	9.00	B3815	A3541	915076	25501L	50-007-001
VOLVO	EC150LC			1.496	8.1875	7.50	B3635	A3541	915234	25500	50-007-010