



WTC MACHINERY Engineered to perform. Built to last.

WTC Machinery is a global leader in designing and building machinery and tooling for heavy equipment repair facilities.

200T Track Press

Overview

With 200 tons of pressing force on each of its two rams, the 200T works tracks up to and beyond 9½" (240 mm) Pitch. The 200T Track Press comes standard with 30 feet (9,14 meter) of conveyor with longer lengths available. Add on WTC Machinery's Pad Lifter and a Track Wrench for a complete track service system.

Features in the 200T Track Press include a Guard door to protect the operator and a hydraulic powered high-mount winch giving them a clear view of the cable and track. The high ram speed shortens rebuilding times while the index table effortlessly moves the track in and out of the work area

The 200T track press accepts WTC Machinery 91-Series, 93-Series and C-Style tooling. With tool mounts that precisely adjust in all directions and with the optional jaw adapters all existing tooling used on Wolf, Trackmaster, Centurion or Mattson track presses can also be used.

Including the optional Pad Lifter eliminates the need to remove the shoes during pin and bushing turns while the optional wireless remote control for the winch and pad lifter allows the operator the freedom to move around the press and conveyor for easy inspection while still performing various operations.



Specifications:

Main Rams (x 2)

Pressing Force:	200/182 Tons	
Travel:	7-7/8" (200 mm)	
Diameter:	Ram 7.5" (190 mm) Piston 8" (203 mm)	
Ram Speed:	50 Cycle	60 Cycle
Approach:	63 IPM (1,60 m/min)	76 IPM (1,9 m/min)
Pressing:	17 IPM (0,4 m/min)	21 IPM (0,5 m/min)
Return:	145 IPM (3,7 m/min)	171 IPM (4,3 m/min)

Electrical

Main Motor:	20 Hp (14.9 kW)
Standard Voltages:	Three Phase
	208V / 60 Hz
	220V / 50 Hz
	230V / 60 Hz
	380V / 50 Hz
	440V / 50 Hz
	460V / 60 Hz

Winch 9,000 lbs (4090 kg) Capacity

200T-000 Track Press Specifications

DIMENSIONS

Weight ... 8400 lbs (3820 kg)	Width (Depth) (without conveyors)..... 117 inches (3,0 m)
Length 101 inches (2,6 m)	Height 66 inches (1,7 m)
Operating Temperature Range 50° to 100° F (10° to 37° C)	

RAMS

Capacity ... 200 tons (182 t), each ram	Speeds -	
Travel 7-7/8 inches (200 mm)	50 Cycle	60 Cycle
Ram Diameter: 7.5 inches (190 mm)	Approach 63 IPM (1,6 m/min)	76 IPM (1,9 m/min)
Piston Diameter: 8 inches (203 mm)	Pressing 17 IPM (0,4 m/min)	21 IPM (0,5 m/min)
	Return 145 IPM (3,7 m/min)	171 IPM (4,3 m/min)

HYDRAULIC PUMP UNIT

Pumps -

High Pressure Pump 4.76 gpm (18,0 lpm)
7960 psi (545 atm.) max.
Low Pressure Pump 12.00 gpm (45.5 lpm)
2000 psi (136 atm) max.

Reservoir -

Total - 50 US gallons (190 l)
Usable - 35 US gallons (132 l)

Oil Type -

ISO 32, SUS 50 to 300 over 70° to 180° F range. Pressure rating to 8,000 p.s.i.
Anti-wear additives suited to hydraulic pumps.

Electric Motor -

20 Hp (14.9 kW) 3 Phase electric.
Standard Voltages:
50 Hz (1500 rpm) **60 Hz (1800 rpm)**
440V/29A, 460V/27A
380V/30A 230V/54A
220V/56A 208V/60A
Other voltages available

POWER WINCH

Hydraulically operated power winch with 9,000 pound (4090 kg) pulling capacity.

INDEX TABLE

Hydraulically operated Index Table moves track in and out of work area.
- 200C-000 version - Continuous Chain Index Table
- 200-000 version – Stroking Cylinder Index Table

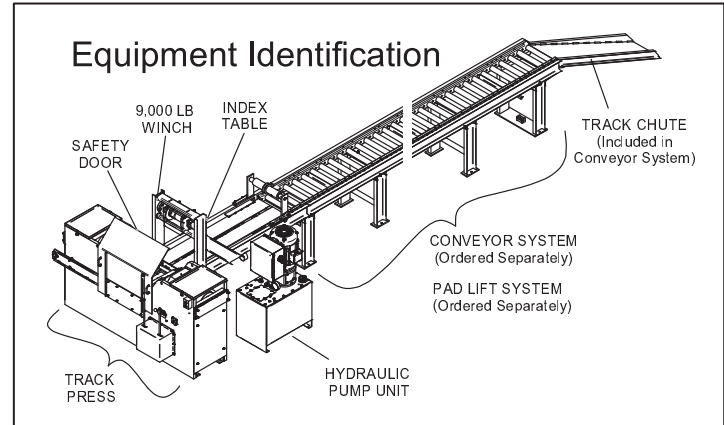

CONVEYOR SYSTEM

Medium Duty Conveyor System – (sold separately) 30-foot (9,1 m), 40-foot (12,2 m) or 50-foot (15,2 m)
Conveyor Systems support the track chain for pad shoe work and easy movement by the Index Table.

Optional Pad Lifting Devices - Available in 30-foot (9,1 m) (**D1429-030-DA**), 40-foot (12,2 m) (**D1429-040-DA**) or 50-foot (15,2 m) (**D1429-050-DA**) lengths, the optional pad lift system hydraulically raises and lowers pad shoes from the track chain, reducing disassembly and assembly labor.

SPECIFICATIONS SUBJECT TO CHANGE WITHOUT NOTICE

Control Identification

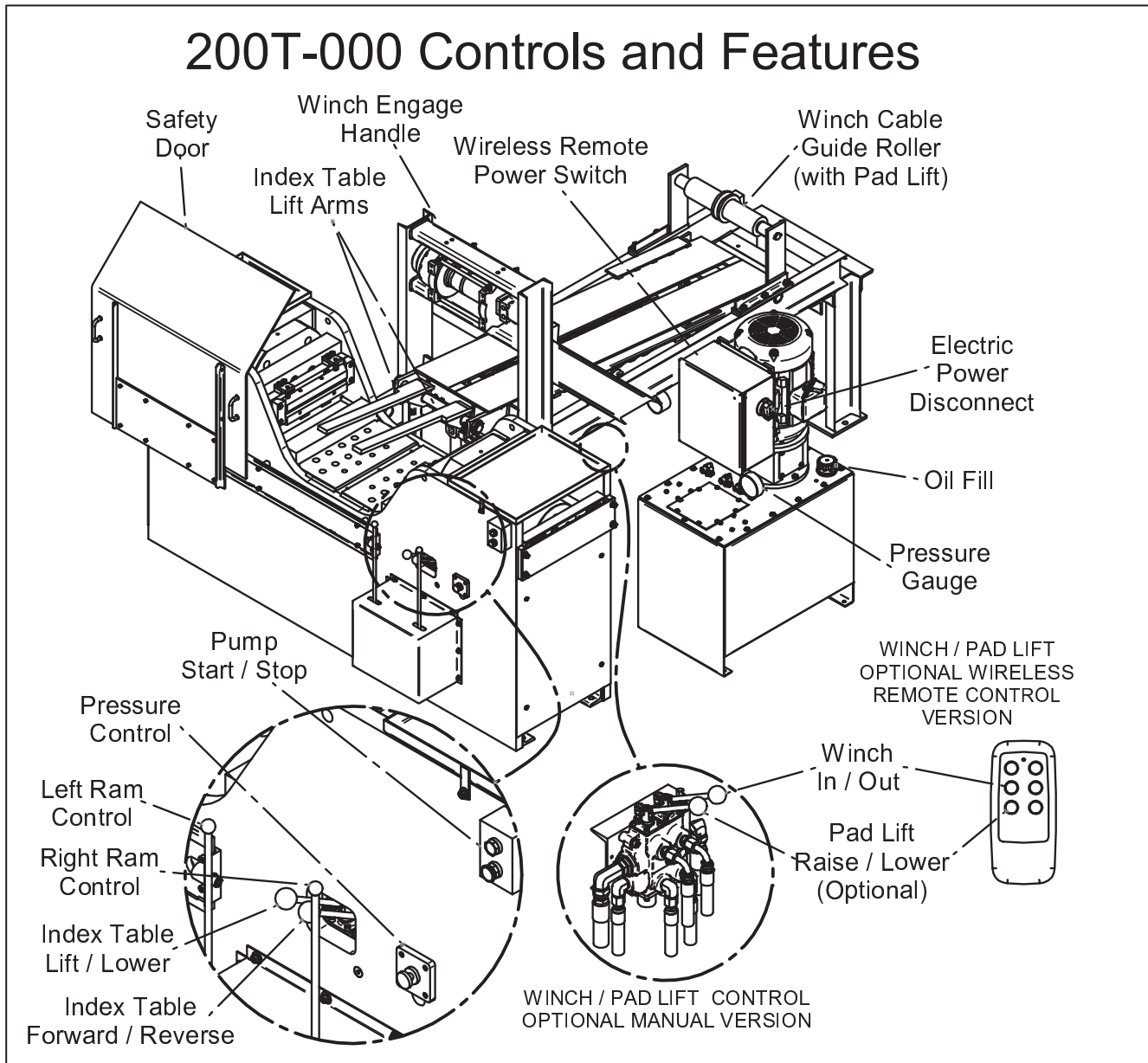

Left Ram Control - extends and retracts the Left Ram)

Move the Left Ram Control to the **right** to extend the Left Ram, and move the Left Ram Control to the **left** to retract the Left Ram.

Right Ram Control - extends and retracts the Right Ram

Move the Right Ram Control to the **left** to extend the Right Ram, and move the Right Ram Control to the **right** to retract the Right Ram.

Control Identification (Continued)

Index Table Lift / Lower Control - raises and lowers the Index Table

Push down on the Control to lower the Index Table.

Pull up on the Lift / Lower Control to lift the Index Table.

Index Table Forward / Reverse Control - moves the Index Table Pawl, and the track chain

Push down on the Forward / Reverse Control to move the track chain away from the operator.

Pull up on the Control to move the track chain toward the operator.

(See the Maintenance Section for adjusting the Index Table Forward / Reverse speed.)

Pump Start / Stop - starts and stops the Electric Motor which power the Track Press

Press the **Start** Push Button to start the Electric Motor.

Press the **Stop** Push Button to stop the Electric Motor.

Pressure Control - sets the system pressure, and the ram force

Turn the Pressure Control's knob **clockwise** to increase the operating pressure.

Turn the Pressure Control's knob **counterclockwise** to decrease the operating pressure.

Use the jam nut (behind the adjustment knob) to lock the Pressure Control at a particular setting.

Pressure Gauge - shows the system pressure

See the Force Table (page 18) and the Track Assembly Label on the Press for the pressure needed to assemble selected types of track chain.

Manual Winch Control (200-MW and 200-MWP) - pays out and reels in the winch cable

Push Down on the Winch Control to reel in the winch cable, pulling the track chain.

Pull Up on the Winch Control to pay out the Winch Cable -

NOTE- The Winch cable can be manually payed out when the Winch is Disengaged.

**WARNING!**

The Winch Cable can entrap objects and personnel, and can cause serious injury if it breaks while under tension.

Always inspect the Winch Cable before use. Replace the Cable if it is worn, frayed or "cork-screwed".

Always make the sure personnel and obstructions are clear of the Winch Cable and track chain before pulling.

Before use, always cover the center of the Cable with a safety blanket to prevent whipping if the cable does break.

Always make sure the Winch Cable is securely attached to the track chain before pulling.

Manual Pad Lift Control (200-MWP) – raises and lowers the Optional Pad Lift System

Push Down on the Pad Lift Control to lower the Pad Lift System.

Pull Up on the Pad Lift Control to raise the Pad Lift System.

**WARNING!**

The Optional Pad Lift System contains Pinch Points which can cause serious injury and can damage equipment.

Always make sure personnel and equipment are clear of the Pad Lift System before operating.



W1222 LINDEN ROAD, IXONIA, WISCONSIN 53036 USA

Phone: 800-248-8405 or 262-567-3993 • Fax: 262-567-4307 www.wtcmachinery.com

MANUFACTURERS/BENEFICIARY'S WARRANTY CERTIFICATE WTC MACHINERY, LLC WARRANTY

WTC MACHINERY, LLC warrants its products to be free from defects in material and workmanship under normal use and service for a period of twelve (12) months after date of shipment. WTC MACHINERY, LLC undertakes to be responsible for any defect that may arise due to faulty raw materials, design, workmanship and defective parts and to replace them without extra cost. Freight charges are the customer's responsibility. Our warranty is not transferable.

WTC MACHINERY, LLC shall have the option of requiring the return of all parts claimed defective. Parts proved to be defective, due to defect in workmanship and/or material, shall be either repaired or replaced free of charge, F.O.B. our designated factory. All parts warranty claims are subject to inspection by WTC MACHINERY, LLC and acceptance at the factory

Our warranty does not obligate us to bear the cost of labor or transportation charges in connection with the replacement or repair of defective parts and the removal and/or remounting of the parts repaired or replaced under this warranty, unless specifically authorized in writing by WTC MACHINERY, LLC. All parts returned to the factory must be shipped freight prepaid; no collect freight will be accepted by the factory. Forms authorizing such returns for inspection must accompany all returns.

This warranty shall not apply to products not manufactured by WTC MACHINERY, LLC.

Outside purchased equipment and accessories (not of WTC manufacture) are warranted only to the extent of the original equipment manufacturer's warranty and subject to their allowance to WTC MACHINERY, LLC. In this respect, our warranty obligations must conform and be limited to the warranty extended to WTC MACHINERY, LLC by its suppliers as extended to the customer.

We shall, in no event, be liable for consequential damages or contingent liability arising out of the failure of any unit or part to operate properly, or that is subject to:

- Ordinary operating wear, abuse, misuse, or overloading;
- Repairs or alterations by parties other than WTC MACHINERY, LLC;
- The use of improper fluids, contaminated fluids or improper filtering;
- The use of improper voltage hookup in the electrical connections of any equipment;
- Negligence, accident or damages due to deterioration during periods of storage by the purchaser prior to installation and operation;
- Damages occurred in shipment after leaving factory en route to customers' delivery point, as title to equipment passes to customer when loaded onboard for shipment, f.o.b. factory, and customer must place his own claim against damaged goods directly to the shipping company and not against WTC MACHINERY, LLC, its factory, or any of its personnel.
- Damages due to circumstances beyond the control of WTC MACHINERY, LLC and in connection with fulfilling any obligation under this warranty.

To the maximum extent permitted by applicable law, in no event shall WTC Machinery, LLC be liable for indirect, special, incidental or consequential damages resulting from personal injury, loss of business profits or business interruption from the use of its products, or from the inability to use its products.

This warranty is exclusive and is in lieu of all other expressed and implied warranties, including but not limited to implied warranties or merchantability and fitness for a particular purpose. WTC MACHINERY, LLC shall not be subject to any other obligations or liabilities whatsoever with respect to equipment manufactured or supplied by WTC MACHINERY, LLC, or services rendered to it.